

TEST REPORT
IEC/EN 62368-1
Audio/video, information and communication technology equipment
Part 1: Safety requirements

Report Number: AST-OR-24062603

Date of issue: 2024-08-30

Total number of pages: 81

Tested by (name, signature).....:

Edward Lu 

Approved by (name, signature).....: Ricky Liu

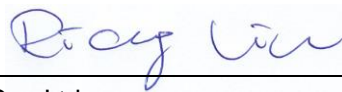

Name of Testing Laboratory preparing the Report: Ansett Lab Co., Ltd.
 4F., No. 16, Alley 8, Lane 45, Baoxing Road, Xindian Dist., New Taipei City 231, Taiwan

Applicant's name: Vecow Co., Ltd
 Address.....: 3F, No. 10, Jiankang Rd., Zhonghe Dist., New Taipei City 23586, Taiwan

Test specification:

Standard.....: IEC 62368-1: 2018
 EN 62368-1: 2020 + A11: 2020
 BS EN IEC 62368-1: 2020 + A11: 2020

Test procedure.....: Test report

Non-standard test method: N/A

Test Report Form No.: AST-R-111

Test Report Form(s) Originator.....: AST

Master TRF.....: 2020/11/09

Test item description..... :	Rugged Embedded System
Trade Mark..... :	N/A
Manufacturer..... :	Vecow Co., Ltd 3F, No. 10, Jiankang Rd., Zhonghe Dist., New Taipei City 23586, Taiwan
Model/Type reference..... :	ECS-4700-PoER, ECS-4XXXXXXXXXX ("X" can be 0-9, A-Z or blank for marketing purpose)
Ratings..... :	9-50 V d.c., 20 A

<p>List of Attachments (including a total number of pages in each attachment): ATTACHMENT 1: National differences ACHMENT 2: Photographs Unless otherwise specified, each attachment has been included in the total number of pages.</p>	
<p>Summary of testing: See below for summary and applicable clauses. All tests were conducted in Maximum Normal Load conditions as below, if not specified elsewhere. Maximum Normal Load: - Each USB 3.1 port load 5 V/0.9 A, 4.5 W. - Each USB 2.0 port load 5 V/0.5 A, 2.5 W. - USB-C port load 5 V/0.9 A, 4.5 W - HDMI ports connected to Monitor. - RJ-45 port transmitting data. - Cross reading and writing data between HDD in maximum speed. - PoE Budget: each port 25 W, total 35 W Max.</p>	
<p>Tests performed (name of test and test clause):</p> <ul style="list-style-type: none"> - Steady Force Test (4.4.3.2, T.5) - Enclosure Impact Test (4.4.3.4, T.6) - Classification of electrical energy sources (5.2) - Power source circuit classifications (6.2.2) - Temperature Test (5.4.1.4, 9.3, B.1.5, B.2.6) - Input Test (B.2.5) - Abnormal Operating and Fault Condition Tests (B.3, B.4) - Test For The Permanence Of Markings (Annex F.3.10) - Batteries charging circuit test (M.3.2) - Limited Power Source (Annex Q.1) 	<p>Testing location: Ansett Lab Co., Ltd. 4F., No. 16, Alley 8, Lane 45, Baoxing Road, Xindian Dist., New Taipei City 231, Taiwan</p>
<p>Summary of compliance with National Differences (List of countries addressed): EU Group differences, special national deviations of all CENELEC countries. Explanation of CENELEC countries: Austria (AT), Belgium (BE), Bulgaria (BG), Croatia (HR), Cyprus (CY), Czech Republic (CZ), Denmark (DK), Estonia (EE), Finland (FI), France (FR), Germany (DE), Greece (GR), Hungary (HU), Iceland (IS), Ireland (IE), Italy (IT), Latvia (LV), Lithuania (LT), Luxembourg (LU), Malta (MT), Netherlands (NL), Norway (NO), Poland (PL), Portugal (PT), Romania (RO), Spain (ES), Slovakia (SK), Slovenia (SI), Sweden (SE), Switzerland (CH) and United Kingdom (GB). <input checked="" type="checkbox"/> The product fulfils the requirements of IEC 62368-1: 2018, EN IEC 62368-1: 2020 + A11: 2020 and BS EN IEC 62368-1: 2020 + A11: 2020.</p>	

Copy of marking plate:

The artwork below may be only a draft. The use of certification marks on a product must be authorized by the respective NCBs that own these marks.

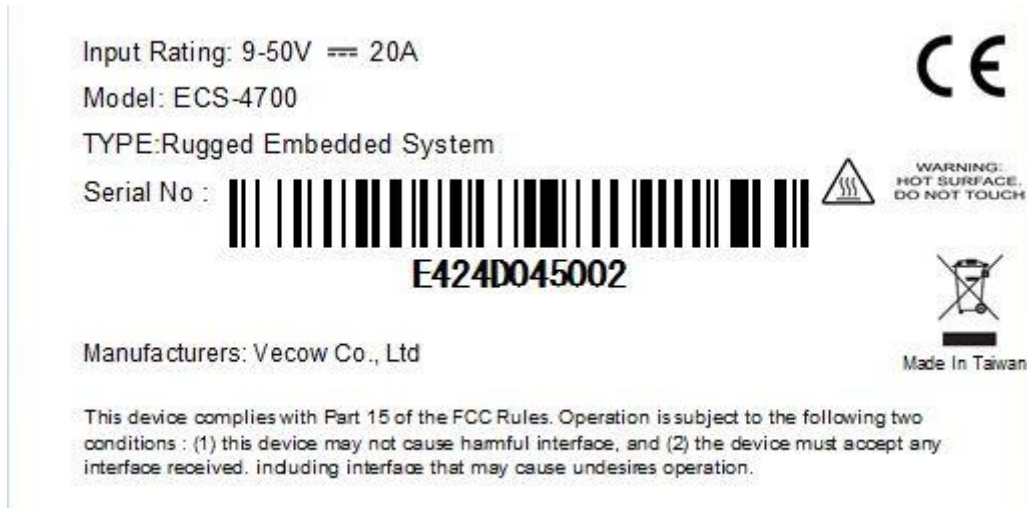

Note:

The above markings are the minimum requirements required by the safety standard. For the final production samples, the additional markings which do not give rise to misunderstanding may be added. Because information of importer has not been confirmed, the information of importer will be given on label by manufacturer prior to marketing in the EEC.

Test item particulars:			
Product group	<input checked="" type="checkbox"/> end product	<input type="checkbox"/> built-in component	
Classification of use by	<input type="checkbox"/> Ordinary person	<input type="checkbox"/> Children likely present	
	<input checked="" type="checkbox"/> Instructed person		
	<input checked="" type="checkbox"/> Skilled person		
Supply connection	<input type="checkbox"/> AC mains	<input type="checkbox"/> DC mains	
	<input checked="" type="checkbox"/> not mains connected:		
	<input checked="" type="checkbox"/> ES1	<input type="checkbox"/> ES2	<input type="checkbox"/> ES3
Supply tolerance	<input type="checkbox"/> +10%/-10%		
	<input type="checkbox"/> +20%/-15%		
	<input type="checkbox"/> + %/ - %		
	<input checked="" type="checkbox"/> None		
Supply connection – type	<input type="checkbox"/> pluggable equipment type A -		
	<input type="checkbox"/> non-detachable supply cord		
	<input type="checkbox"/> appliance coupler		
	<input type="checkbox"/> direct plug-in		
	<input type="checkbox"/> pluggable equipment type B -		
	<input type="checkbox"/> non-detachable supply cord		
	<input type="checkbox"/> appliance coupler		
	<input type="checkbox"/> permanent connection		
	<input checked="" type="checkbox"/> mating connector	<input checked="" type="checkbox"/> other: DC Supply	
Considered current rating of protective device	Location:	<input type="checkbox"/> building	<input type="checkbox"/> equipment
	<input checked="" type="checkbox"/> N/A		
Equipment mobility	<input checked="" type="checkbox"/> movable	<input type="checkbox"/> hand-held	<input type="checkbox"/> transportable
	<input type="checkbox"/> direct plug-in	<input type="checkbox"/> stationary	<input type="checkbox"/> for building-in
	<input type="checkbox"/> wall/ceiling-mounted	<input type="checkbox"/> SRME/rack-mounted	
	<input type="checkbox"/> other:		
Overvoltage category (OVC)	<input type="checkbox"/> OVC I	<input type="checkbox"/> OVC II	<input type="checkbox"/> OVC III
	<input type="checkbox"/> OVC IV	<input checked="" type="checkbox"/> other: Not directly connected to the mains	
Class of equipment	<input type="checkbox"/> Class I	<input type="checkbox"/> Class II	<input checked="" type="checkbox"/> Class III
	<input type="checkbox"/> Not classified		
Special installation location	<input checked="" type="checkbox"/> N/A	<input type="checkbox"/> restricted access area	
	<input type="checkbox"/> outdoor location		
Pollution degree (PD)	<input type="checkbox"/> PD 1	<input checked="" type="checkbox"/> PD 2	<input type="checkbox"/> PD 3
Manufacturer’s specified T_{ma}	45 °C	<input type="checkbox"/> Outdoor: minimum	°C
IP protection class	<input checked="" type="checkbox"/> IPX0	<input type="checkbox"/> IP__	
Power systems	<input type="checkbox"/> TN	<input type="checkbox"/> TT	<input type="checkbox"/> IT - V _{L-L}
	<input checked="" type="checkbox"/> not AC mains		
Altitude during operation (m)	<input checked="" type="checkbox"/> 2000 m or less	<input type="checkbox"/>	m
Altitude of test laboratory (m)	<input checked="" type="checkbox"/> 2000 m or less	<input type="checkbox"/>	m
Mass of equipment (kg)	2.25 kg		

<p>Possible test case verdicts:</p> <ul style="list-style-type: none"> - test case does not apply to the test object ... : N/A - test object does meet the requirement : P (Pass) - test object does not meet the requirement ... : F (Fail)
<p>Testing:</p> <p>Date of receipt of test item : 2024-07-12</p> <p>Date (s) of performance of tests..... : 2024-07-12 ~ 2024-08-09</p>
<p>General remarks:</p> <p>"(See Enclosure #)" refers to additional information appended to the report. "(See appended table)" refers to a table appended to the report.</p> <p>Throughout this report a <input type="checkbox"/> comma / <input checked="" type="checkbox"/> point is used as the decimal separator. The instructions specified by the standard have to be in official language of each country, however, only English is checked for this report. It is the applicant responsibility to provide instruction in each official language of the EU.</p> <p>This report is submitted for the exclusive use of the client to whom it is addressed. Its significance is subject to the adequacy and representative character of the sample(s) and to the comprehensiveness of the tests, examinations or surveys made.</p> <p>This report justified only the submitted samples exclusively and not necessarily implies that all other samples are also to be found in same result.</p> <p>The CE marking may only be used if all relevant and effective EC directives are complied with.</p> <p>The measurement uncertainty is not accounted for the decision rule in statement of conformity.</p>
<p>When differences exist; they shall be identified in the General product information section.</p>
<p>Name and address of factory (ies) : Vecow Co., Ltd</p> <p style="text-align: right;">3F, No. 10, Jiankang Rd., Zhonghe Dist., New Taipei City 23586, Taiwan</p>
<p>General product information and other remarks:</p> <p>The product has been additionally evaluated and considered in compliance with standard BS EN IEC 62368-1:2020+A11:2020, content of UK compliance refers to European Group Differences and National Difference EU_GD_IEC62368_1E.</p> <p>The equipment is a Rugged Embedded System as audio/video, information and communication technology equipment.</p> <p>The outputs of data ports are in accordance with the Limited Power Sources (Annex Q), see appended table Annex Q.1 details.</p> <p>The LAN connector of the subject model is to be used with other IT equipment via Ethernet Networks in the same building. There is no connection to ES2 or ES3 of external circuit.</p> <p>The equipment is intended to be supplied by approval external DC power source which output is complied with ES1 rated 9-50 Vdc, 20 A minimum and maximum ambient temperature 45°C minimum.</p>
<p>Model Differences:</p> <p>All models are identical to each other except for the model designation for marketing purpose only.</p>

<p>Explanation of model designation ECS-4XXXXXXXXXX: The "X" can be 0-9, A-Z or blank for the marketing purpose only, no safety concern.</p>
--

OVERVIEW OF ENERGY SOURCES AND SAFEGUARDS				
Clause	Possible Hazard			
5	Electrically-caused injury			
Class and Energy Source (e.g. ES3: Primary circuit)	Body Part (e.g. Ordinary)	Safeguards		
		B	S	R
ES1: All circuits	Instructed person, Skilled person	N/A	N/A	N/A
ES1: Output terminals and accessible parts	Instructed person, Skilled person	N/A	N/A	N/A
6	Electrically-caused fire			
Class and Energy Source (e.g. PS2: 100 Watt circuit)	Material part (e.g. Printed board)	Safeguards		
		B	1 st S	2 nd S
PS3 Circuit	Enclosure	See 6.3	Metal	N/A
PS3 Circuit	PCB	See 6.3	Minimum V-1.	N/A
PS3 Circuit	Other Components/Materials	See 6.3	See 6.4.5 and 6.4.6	N/A
PS3 Circuit	Internal Wiring	N/A	N/A	See 6.5
PS1/PS2 (LPS)	Output Ports	See 6.3	See 6.4.5	N/A
7	Injury caused by hazardous substances			
Class and Energy Source (e.g. Ozone)	Body Part (e.g., Skilled)	Safeguards		
		B	S	R
RTC Battery (Lithium)	Instructed person, Skilled person	N/A	N/A	See clause Annex M
8	Mechanically-caused injury			
Class and Energy Source (e.g. MS3: Plastic fan blades)	Body Part (e.g. Ordinary)	Safeguards		
		B	S	R
MS1: Edges and corners	Instructed person, Skilled person	Rounded edges and corners	N/A	N/A
MS1: Equipment mass	Instructed person, Skilled person	N/A	N/A	N/A
9	Thermal burn			
Class and Energy Source (e.g. TS1: Keyboard caps)	Body Part (e.g., Ordinary)	Safeguards		
		B	S	R
TS3: Internal Parts	Instructed person, Skilled person	N/A	N/A	Enclosure
TS2: Metal Accessible Part (Enclosure)	Instructed person, Skilled person	N/A	N/A	N/A
10	Radiation			

Class and Energy Source (e.g. RS1: PMP sound output)	Body Part (e.g., Ordinary)	Safeguards		
		B	S	R
RS1: LED indicators	Instructed person, Skilled person	N/A	N/A	N/A
Supplementary Information: “B” – Basic Safeguard; “S” – Supplementary Safeguard; “R” – Reinforced Safeguard				

ENERGY SOURCE DIAGRAM

Optional. Manufacturers are to provide the energy sources diagram identify declared energy sources and identifying the demarcations are between power sources. Recommend diagram be provided included in power supply and multipart systems.

Insert diagram below. Example diagram designs are; Block diagrams; image(s) with layered data; mechanical drawings

ES PS MS TS RS

IEC/EN 62368-1			
Clause	Requirement + Test	Result - Remark	Verdict

4	GENERAL REQUIREMENTS		P
4.1.1	Acceptance of materials, components and subassemblies	Components which were found to affect safety aspects comply with the requirements of this standard or within the safety aspects of the relevant IEC component standards. (See appended table 4.1.2).	P
4.1.2	Use of components	Components which are certified to IEC and/or national standards are used correctly within their ratings. Components not covered by IEC standards are tested under the conditions present in the equipment.	P
4.1.3	Equipment design and construction	Compliance is checked by inspection and by the relevant tests of Annex B.2, Annex B.3 and Annex B.4.	P
4.1.4	Specified ambient temperature for outdoor use (°C) :		N/A
4.1.5	Constructions and components not specifically covered		N/A
4.1.8	Liquids and liquid filled components (LFC)		N/A
4.1.15	Markings and instructions	(See Annex F)	P
4.4.3	Safeguard robustness		P
4.4.3.1	General		P
4.4.3.2	Steady force tests	(See Annex T.5)	P
4.4.3.3	Drop tests		N/A
4.4.3.4	Impact tests	(See Annex T.6)	P
4.4.3.5	Internal accessible safeguard tests		N/A
4.4.3.6	Glass impact tests		N/A
4.4.3.7	Glass fixation tests		N/A
	Glass impact test (1J)		N/A
	Push/pull test (10 N)		N/A
4.4.3.8	Thermoplastic material tests		N/A
4.4.3.9	Air comprising a safeguard	(See Annex T)	P
4.4.3.10	Accessibility, glass, safeguard effectiveness		N/A
4.4.4	Displacement of a safeguard by an insulating liquid		N/A

IEC/EN 62368-1			
Clause	Requirement + Test	Result - Remark	Verdict
4.4.5	Safety interlocks		N/A
4.5	Explosion		P
4.5.1	General		P
4.5.2	No explosion during normal/abnormal operating condition	(See Annex B.2, B.3)	P
	No harm by explosion during single fault conditions	(See Annex B.4)	P
4.6	Fixing of conductors		N/A
	Fix conductors not to defeat a safeguard		N/A
	Compliance is checked by test..... :		N/A
4.7	Equipment for direct insertion into mains socket-outlets		N/A
4.7.2	Mains plug part complies with relevant standard .. :	EUT is not Direct plug-in type equipment.	N/A
4.7.3	Torque (Nm)		N/A
4.8	Equipment containing coin/button cell batteries		N/A
4.8.1	General	Construction of RTC battery is unlikely to be accessible to children	N/A
4.8.2	Instructional safeguard..... :		N/A
4.8.3	Battery compartment door/cover construction		N/A
	Open torque test		N/A
4.8.4.2	Stress relief test		N/A
4.8.4.3	Battery replacement test		N/A
4.8.4.4	Drop test		N/A
4.8.4.5	Impact test		N/A
4.8.4.6	Crush test		N/A
4.8.5	Compliance		N/A
	30N force test with test probe		N/A
	20N force test with test hook		N/A
4.9	Likelihood of fire or shock due to entry of conductive object		N/A
4.10	Component requirements		N/A
4.10.1	Disconnect Device		N/A
4.10.2	Switches and relays		N/A
5	ELECTRICALLY-CAUSED INJURY		P
5.2	Classification and limits of electrical energy sources		P

IEC/EN 62368-1			
Clause	Requirement + Test	Result - Remark	Verdict
5.2.2	ES1, ES2 and ES3 limits	All Secondary circuits in external power adapter and I/O connector are considered as ES1.	P
5.2.2.2	Steady-state voltage and current limits	(See appended table 5.2)	P
5.2.2.3	Capacitance limits		N/A
5.2.2.4	Single pulse limits.....		N/A
5.2.2.5	Limits for repetitive pulses.....		N/A
5.2.2.6	Ringing signals		N/A
5.2.2.7	Audio signals		N/A
5.3	Protection against electrical energy sources		N/A
5.3.1	General Requirements for accessible parts to ordinary, instructed and skilled persons		N/A
5.3.1 a)	Accessible ES1/ES2 derived from ES2/ES3 circuits		N/A
5.3.1 b)	Skilled persons not unintentional contact ES3 bare conductors		N/A
5.3.2.1	Accessibility to electrical energy sources and safeguards		N/A
	Accessibility to outdoor equipment bare parts		N/A
5.3.2.2	Contact requirements		N/A
	Test with test probe from Annex V		—
5.3.2.2 a)	Air gap – electric strength test potential (V).....		N/A
5.3.2.2 b)	Air gap – distance (mm)		N/A
5.3.2.3	Compliance		N/A
5.3.2.4	Terminals for connecting stripped wire		N/A
5.4	Insulation materials and requirements		N/A
5.4.1.2	Properties of insulating material		N/A
5.4.1.3	Material is non-hygroscopic		N/A
5.4.1.4	Maximum operating temperature for insulating materials		N/A
5.4.1.5	Pollution degrees	Pollution degree 2.	N/A
5.4.1.5.2	Test for pollution degree 1 environment and for an insulating compound		N/A
5.4.1.5.3	Thermal cycling test		N/A
5.4.1.6	Insulation in transformers with varying dimensions		N/A
5.4.1.7	Insulation in circuits generating starting pulses		N/A
5.4.1.8	Determination of working voltage		N/A

IEC/EN 62368-1			
Clause	Requirement + Test	Result - Remark	Verdict
5.4.1.9	Insulating surfaces		N/A
5.4.1.10	Thermoplastic parts on which conductive metallic parts are directly mounted		N/A
5.4.1.10.2	Vicat test..... :		N/A
5.4.1.10.3	Ball pressure test..... :		N/A
5.4.2	Clearances	Only functional insulation required	N/A
5.4.2.1	General requirements		N/A
	Clearances in circuits connected to AC Mains, Alternative method		N/A
5.4.2.2	Procedure 1 for determining clearance		N/A
	Temporary overvoltage :		—
5.4.2.3	Procedure 2 for determining clearance		N/A
5.4.2.3.2.2	a.c. mains transient voltage :		—
5.4.2.3.2.3	d.c. mains transient voltage :		—
5.4.2.3.2.4	External circuit transient voltage..... :		—
5.4.2.3.2.5	Transient voltage determined by measurement :		—
5.4.2.4	Determining the adequacy of a clearance using an electric strength test :		N/A
5.4.2.5	Multiplication factors for clearances and test voltages :		N/A
5.4.2.6	Clearance measurement :	Only functional insulation required	N/A
5.4.3	Creepage distances		N/A
5.4.3.1	General		N/A
5.4.3.3	Material group..... :		—
5.4.3.4	Creepage distances measurement..... :		N/A
5.4.4	Solid insulation		N/A
5.4.4.1	General requirements		N/A
5.4.4.2	Minimum distance through insulation :		N/A
5.4.4.3	Insulating compound forming solid insulation		N/A
5.4.4.4	Solid insulation in semiconductor devices		N/A
5.4.4.5	Insulating compound forming cemented joints		N/A
5.4.4.6	Thin sheet material		N/A
5.4.4.6.1	General requirements		N/A
5.4.4.6.2	Separable thin sheet material		N/A

IEC/EN 62368-1			
Clause	Requirement + Test	Result - Remark	Verdict
	Number of layers (pcs)		N/A
5.4.4.6.3	Non-separable thin sheet material		N/A
	Number of layers (pcs)		N/A
5.4.4.6.4	Standard test procedure for non-separable thin sheet material.....		N/A
5.4.4.6.5	Mandrel test		N/A
5.4.4.7	Solid insulation in wound components		N/A
5.4.4.9	Solid insulation at frequencies >30 kHz, E_P , K_R , d , V_{PW} (V)		N/A
	Alternative by electric strength test, tested voltage (V), K_R		N/A
5.4.5	Antenna terminal insulation		N/A
5.4.5.1	General		N/A
5.4.5.2	Voltage surge test		N/A
5.4.5.3	Insulation resistance (M Ω)		N/A
	Electric strength test		N/A
5.4.6	Insulation of internal wire as part of supplementary safeguard		N/A
5.4.7	Tests for semiconductor components and for cemented joints		N/A
5.4.8	Humidity conditioning		N/A
	Relative humidity (%), temperature ($^{\circ}$ C), duration (h)		—
5.4.9	Electric strength test		N/A
5.4.9.1	Test procedure for type test of solid insulation.....		N/A
5.4.9.2	Test procedure for routine test		N/A
5.4.10	Safeguards against transient voltages from external circuits		N/A
5.4.10.1	Parts and circuits separated from external circuits		N/A
5.4.10.2	Test methods		N/A
5.4.10.2.1	General		N/A
5.4.10.2.2	Impulse test.....		N/A
5.4.10.2.3	Steady-state test.....		N/A
5.4.10.3	Verification for insulation breakdown for impulse test		N/A
5.4.11	Separation between external circuits and earth		N/A
5.4.11.1	Exceptions to separation between external circuits and earth		N/A

IEC/EN 62368-1			
Clause	Requirement + Test	Result - Remark	Verdict
5.4.11.2	Requirements		N/A
	SPDs bridge separation between external circuit and earth		N/A
	Rated operating voltage U_{op} (V)..... :		—
	Nominal voltage U_{peak} (V) :		—
	Max increase due to variation ΔU_{sp} :		—
	Max increase due to ageing ΔU_{sa} :		—
5.4.11.3	Test method and compliance :		N/A
5.4.12	Insulating liquid		N/A
5.4.12.1	General requirements		N/A
5.4.12.2	Electric strength of an insulating liquid :		N/A
5.4.12.3	Compatibility of an insulating liquid :		N/A
5.4.12.4	Container for insulating liquid :		N/A
5.5	Components as safeguards		N/A
5.5.1	General		N/A
5.5.2	Capacitors and RC units		N/A
5.5.2.1	General requirement		N/A
5.5.2.2	Safeguards against capacitor discharge after disconnection of a connector..... :		N/A
5.5.3	Transformers		N/A
5.5.4	Optocouplers		N/A
5.5.5	Relays		N/A
5.5.6	Resistors		N/A
5.5.7	SPDs		N/A
5.5.8	Insulation between the mains and an external circuit consisting of a coaxial cable :		N/A
5.5.9	Safeguards for socket-outlets in outdoor equipment		N/A
	RCD rated residual operating current (mA) :		—
5.6	Protective conductor		N/A
5.6.2	Requirement for protective conductors		N/A
5.6.2.1	General requirements		N/A
5.6.2.2	Colour of insulation		N/A
5.6.3	Requirement for protective earthing conductors		N/A
	Protective earthing conductor size (mm ²) :		—
	Protective earthing conductor serving as a reinforced safeguard		N/A

IEC/EN 62368-1			
Clause	Requirement + Test	Result - Remark	Verdict
	Protective earthing conductor serving as a double safeguard		N/A
5.6.4	Requirements for protective bonding conductors		N/A
5.6.4.1	Protective bonding conductors		N/A
	Protective bonding conductor size (mm ²)..... :		—
5.6.4.2	Protective current rating (A) :		N/A
5.6.5	Terminals for protective conductors		N/A
5.6.5.1	Terminal size for connecting protective earthing conductors (mm)..... :		N/A
	Terminal size for connecting protective bonding conductors (mm) :		N/A
5.6.5.2	Corrosion		N/A
5.6.6	Resistance of the protective bonding system		N/A
5.6.6.1	Requirements		N/A
5.6.6.2	Test Method :		N/A
5.6.6.3	Resistance (Ω) or voltage drop :		N/A
5.6.7	Reliable connection of a protective earthing conductor		N/A
5.6.8	Functional earthing		N/A
	Conductor size (mm ²)..... :		N/A
	Class II with functional earthing marking :		N/A
	Appliance inlet cl & cr (mm) :		N/A
5.7	Prospective touch voltage, touch current and protective conductor current		N/A
5.7.2	Measuring devices and networks		N/A
5.7.2.1	Measurement of touch current		N/A
5.7.2.2	Measurement of voltage		N/A
5.7.3	Equipment set-up, supply connections and earth connections		N/A
5.7.4	Unearthed accessible parts..... :		N/A
5.7.5	Earthed accessible conductive parts :		N/A
5.7.6	Requirements when touch current exceeds ES2 limits		N/A
	Protective conductor current (mA)..... :		N/A
	Instructional Safeguard :		N/A
5.7.7	Prospective touch voltage and touch current associated with external circuits		N/A
5.7.7.1	Touch current from coaxial cables		N/A

IEC/EN 62368-1			
Clause	Requirement + Test	Result - Remark	Verdict
5.7.7.2	Prospective touch voltage and touch current associated with paired conductor cables		N/A
5.7.8	Summation of touch currents from external circuits		N/A
	a) Equipment connected to earthed external circuits, current (mA)..... :		N/A
	b) Equipment connected to unearthed external circuits, current (mA)..... :		N/A
5.8	Backfeed safeguard in battery backed up supplies		N/A
	Mains terminal ES		N/A
	Air gap (mm)		N/A

IEC/EN 62368-1			
Clause	Requirement + Test	Result - Remark	Verdict
6	ELECTRICALLY- CAUSED FIRE		P
6.2	Classification of PS and PIS		P
6.2.2	Power source circuit classifications	See OVERVIEW OF ENERGY SOURCES AND SAFEGUARDS.	P
6.2.3	Classification of potential ignition sources	See below	P
6.2.3.1	Arcing PIS		N/A
6.2.3.2	Resistive PIS	All components in the equipment are considered as Resistive PIS.	P
6.3	Safeguards against fire under normal operating and abnormal operating conditions		P
6.3.1	No ignition and attainable temperature value less than 90 % defined by ISO 871 or less than 300 °C for unknown materials..... :	No ignition and no such temperature attained within the equipment. (See appended table 5.4.1.5, 6.3.2, 9.0, B.2.6)	P
	Combustible materials outside fire enclosure		N/A
6.4	Safeguards against fire under single fault conditions		P
6.4.1	Safeguard method	Method by control of fire spread applied. See 6.4.5.	P
6.4.2	Reduction of the likelihood of ignition under single fault conditions in PS1 circuits		N/A
6.4.3	Reduction of the likelihood of ignition under single fault conditions in PS2 and PS3 circuits		N/A
6.4.3.1	Supplementary safeguards		N/A
6.4.3.2	Single Fault Conditions..... :		N/A
	Special conditions for temperature limited by fuse		N/A
6.4.4	Control of fire spread in PS1 circuits		P
6.4.5	Control of fire spread in PS2 circuits	See below.	P
6.4.5.2	Supplementary safeguards	Compliance detailed as follows: – Printed board: rated min. V-1 – All other components: at least V-2 except for mounted on min. V-1 material or small parts of combustible material or components complying to relevant IEC standard. (See appended tables 4.1.2 for detail)	P

IEC/EN 62368-1			
Clause	Requirement + Test	Result - Remark	Verdict
6.4.6	Control of fire spread in PS3 circuits		P
6.4.7	Separation of combustible materials from a PIS		N/A
6.4.7.2	Separation by distance		N/A
6.4.7.3	Separation by a fire barrier		N/A
6.4.8	Fire enclosures and fire barriers		P
6.4.8.2	Fire enclosure and fire barrier material properties		P
6.4.8.2.1	Requirements for a fire barrier		N/A
6.4.8.2.2	Requirements for a fire enclosure		P
6.4.8.3	Constructional requirements for a fire enclosure and a fire barrier		P
6.4.8.3.1	Fire enclosure and fire barrier openings		P
6.4.8.3.2	Fire barrier dimensions		N/A
6.4.8.3.3	Top openings and properties		P
	Openings dimensions (mm) :	No openings.	N/A
6.4.8.3.4	Bottom openings and properties		P
	Openings dimensions (mm) :	No openings.	N/A
	Flammability tests for the bottom of a fire enclosure		N/A
	Instructional Safeguard..... :		N/A
6.4.8.3.5	Side openings and properties		P
	Openings dimensions (mm) :	No openings.	N/A
6.4.8.3.6	Integrity of a fire enclosure, condition met: a), b) or c)..... :		N/A
6.4.8.4	Separation of a PIS from a fire enclosure and a fire barrier distance (mm) or flammability rating..... :		N/A
6.4.9	Flammability of insulating liquid..... :		N/A
6.5	Internal and external wiring		P
6.5.1	General requirements	VW-1 wires used, which considered to equivalent to IEC/TS 60695-11-21	P
6.5.2	Requirements for interconnection to building wiring :		N/A
6.5.3	Internal wiring size (mm ²) for socket-outlets :		N/A
6.6	Safeguards against fire due to the connection to additional equipment		P

7	INJURY CAUSED BY HAZARDOUS SUBSTANCES	P
7.2	Reduction of exposure to hazardous substances	N/A
7.3	Ozone exposure	N/A

IEC/EN 62368-1			
Clause	Requirement + Test	Result - Remark	Verdict
7.4	Use of personal safeguards or personal protective equipment (PPE)		N/A
	Personal safeguards and instructions..... :		—
7.5	Use of instructional safeguards and instructions		N/A
	Instructional safeguard (ISO 7010)..... :		—
7.6	Batteries and their protection circuits		P

8	MECHANICALLY-CAUSED INJURY		P
8.2	Mechanical energy source classifications		P
8.3	Safeguards against mechanical energy sources		P
8.4	Safeguards against parts with sharp edges and corners		P
8.4.1	Safeguards		N/A
	Instructional Safeguard..... :		N/A
8.4.2	Sharp edges or corners	MS1: Sharp edge and corners.	P
8.5	Safeguards against moving parts		N/A
8.5.1	Fingers, jewellery, clothing, hair, etc., contact with MS2 or MS3 parts		N/A
	MS2 or MS3 part required to be accessible for the function of the equipment		N/A
	Moving MS3 parts only accessible to skilled person		N/A
8.5.2	Instructional safeguard		N/A
8.5.4	Special categories of equipment containing moving parts		N/A
8.5.4.1	General		N/A
8.5.4.2	Equipment containing work cells with MS3 parts		N/A
8.5.4.2.1	Protection of persons in the work cell		N/A
8.5.4.2.2	Access protection override		N/A
8.5.4.2.2.1	Override system		N/A
8.5.4.2.2.2	Visual indicator		N/A
8.5.4.2.3	Emergency stop system		N/A
	Maximum stopping distance from the point of activation (m)		N/A
	Space between end point and nearest fixed mechanical part (mm)..... :		N/A
8.5.4.2.4	Endurance requirements		N/A
	Mechanical system subjected to 100 000 cycles of operation		N/A

IEC/EN 62368-1			
Clause	Requirement + Test	Result - Remark	Verdict
	- Mechanical function check and visual inspection		N/A
	- Cable assembly		N/A
8.5.4.3	Equipment having electromechanical device for destruction of media		N/A
8.5.4.3.1	Equipment safeguards		N/A
8.5.4.3.2	Instructional safeguards against moving parts		N/A
8.5.4.3.3	Disconnection from the supply		N/A
8.5.4.3.4	Cut type and test force (N)		N/A
8.5.4.3.5	Compliance		N/A
8.5.5	High pressure lamps		N/A
	Explosion test.....		N/A
8.5.5.3	Glass particles dimensions (mm)		N/A
8.6	Stability of equipment		N/A
8.6.1	General	MS1, not exceed 7 kg.	N/A
	Instructional safeguard		N/A
8.6.2	Static stability		N/A
8.6.2.2	Static stability test.....		N/A
8.6.2.3	Downward force test		N/A
8.6.3	Relocation stability		N/A
	Wheels diameter (mm)		—
	Tilt test		N/A
8.6.4	Glass slide test		N/A
8.6.5	Horizontal force test.....		N/A
8.7	Equipment mounted to wall, ceiling or other structure		N/A
8.7.1	Mount means type.....		N/A
8.7.2	Test methods		N/A
	Test 1, additional downwards force (N).....		N/A
	Test 2, number of attachment points and test force (N)		N/A
	Test 3 Nominal diameter (mm) and applied torque (Nm)		N/A
8.8	Handles strength		N/A
8.8.1	General		N/A
8.8.2	Handle strength test		N/A
	Number of handles		—

IEC/EN 62368-1			
Clause	Requirement + Test	Result - Remark	Verdict
	Force applied (N)		N/A
8.9	Wheels or casters attachment requirements		N/A
8.9.2	Pull test		N/A
8.10	Carts, stands and similar carriers		N/A
8.10.1	General		N/A
8.10.2	Marking and instructions		N/A
8.10.3	Cart, stand or carrier loading test		N/A
	Loading force applied (N).....		N/A
8.10.4	Cart, stand or carrier impact test		N/A
8.10.5	Mechanical stability		N/A
	Force applied (N)		N/A
8.10.6	Thermoplastic temperature stability		N/A
8.11	Mounting means for slide-rail mounted equipment (SRME)		N/A
8.11.1	General		N/A
8.11.2	Requirements for slide rails		N/A
	Instructional Safeguard.....		N/A
8.11.3	Mechanical strength test		N/A
8.11.3.1	Downward force test, force (N) applied.....		N/A
8.11.3.2	Lateral push force test		N/A
8.11.3.3	Integrity of slide rail end stops		N/A
8.11.4	Compliance		N/A
8.12	Telescoping or rod antennas		N/A
	Button/ball diameter (mm).....		—

9	THERMAL BURN INJURY		P
9.2	Thermal energy source classifications		P
9.3	Touch temperature limits		P
9.3.1	Touch temperatures of accessible parts	(See appended table 5.4.1.4, 6.3.2, 9.0, B.2.6, B.3, B.4)	P
9.3.2	Test method and compliance		P
9.4	Safeguards against thermal energy sources		P
9.5	Requirements for safeguards		P
9.5.1	Equipment safeguard		P
9.5.2	Instructional safeguard		N/A
9.6	Requirements for wireless power transmitters		N/A

IEC/EN 62368-1			
Clause	Requirement + Test	Result - Remark	Verdict
9.6.1	General		N/A
9.6.2	Specification of the foreign objects		N/A
9.6.3	Test method and compliance		N/A

10	RADIATION		P
10.2	Radiation energy source classification		P
10.2.1	General classification		P
	Lasers		—
	Lamps and lamp systems	RS1: LED indicators	—
	Image projectors.....		—
	X-Ray		—
	Personal music player.....		—
10.3	Safeguards against laser radiation		N/A
	The standard(s) equipment containing laser(s) comply		N/A
10.4	Safeguards against optical radiation from lamps and lamp systems (including LED types)		P
10.4.1	General requirements	The LED used as indicating light which considered as RS1.	P
	Instructional safeguard provided for accessible radiation level needs to exceed		N/A
	Risk group marking and location		N/A
	Information for safe operation and installation		N/A
10.4.2	Requirements for enclosures		N/A
	UV radiation exposure		N/A
10.4.3	Instructional safeguard.....		N/A
10.5	Safeguards against X-radiation		N/A
10.5.1	Requirements		N/A
	Instructional safeguard for skilled persons.....		—
10.5.3	Maximum radiation (pA/kg)		—
10.6	Safeguards against acoustic energy sources		N/A
10.6.1	General		N/A
10.6.2	Classification		N/A
	Acoustic output $L_{Aeq,T}$, dB(A)		N/A
	Unweighted RMS output voltage (mV).....		N/A

IEC/EN 62368-1			
Clause	Requirement + Test	Result - Remark	Verdict
	Digital output signal (dBFS)		N/A
10.6.3	Requirements for dose-based systems		N/A
10.6.3.1	General requirements		N/A
10.6.3.2	Dose-based warning and automatic decrease		N/A
10.6.3.3	Exposure-based warning and requirements		N/A
	30 s integrated exposure level (MEL30)		N/A
	Warning for MEL ≥ 100 dB(A)		N/A
10.6.4	Measurement methods		N/A
10.6.5	Protection of persons		N/A
	Instructional safeguards		N/A
10.6.6	Requirements for listening devices (headphones, earphones, etc.)		N/A
10.6.6.1	Corded listening devices with analogue input		N/A
	Listening device input voltage (mV)		N/A
10.6.6.2	Corded listening devices with digital input		N/A
	Max. acoustic output $L_{Aeq,T}$, dB(A)		N/A
10.6.6.3	Cordless listening devices		N/A
	Max. acoustic output $L_{Aeq,T}$, dB(A)		N/A

B	NORMAL OPERATING CONDITION TESTS, ABNORMAL OPERATING CONDITION TESTS AND SINGLE FAULT CONDITION TESTS		P
B.1	General		P
B.1.5	Temperature measurement conditions	(See appended table 5.4.1.4, 9.3, B.1.5, B.2.6)	P
B.2	Normal operating conditions		P
B.2.1	General requirements	(See Test Item Particulars and appended test tables)	P
	Audio Amplifiers and equipment with audio amplifiers		N/A
B.2.3	Supply voltage and tolerances		N/A
B.2.5	Input test	(See appended table B.2.5)	P
B.3	Simulated abnormal operating conditions		P
B.3.1	General		P
B.3.2	Covering of ventilation openings		N/A
	Instructional safeguard		N/A
B.3.3	DC mains polarity test		N/A

IEC/EN 62368-1			
Clause	Requirement + Test	Result - Remark	Verdict
B.3.4	Setting of voltage selector		N/A
B.3.5	Maximum load at output terminals	(See appended table B.3, B.4)	P
B.3.6	Reverse battery polarity		N/A
B.3.7	Audio amplifier abnormal operating conditions		N/A
B.3.8	Safeguards functional during and after abnormal operating conditions..... :	All safeguards remained effective.	P
B.4	Simulated single fault conditions		P
B.4.1	General		P
B.4.2	Temperature controlling device		N/A
B.4.3	Blocked motor test	(See appended table B.3, B.4)	P
B.4.4	Functional insulation	No further abnormal tests are necessary, due to faults in primary and secondary components and functional insulation were already evaluated in certified power supply unit.	P
B.4.4.1	Short circuit of clearances for functional insulation		N/A
B.4.4.2	Short circuit of creepage distances for functional insulation		N/A
B.4.4.3	Short circuit of functional insulation on coated printed boards		N/A
B.4.5	Short-circuit and interruption of electrodes in tubes and semiconductors		N/A
B.4.6	Short circuit or disconnection of passive components		N/A
B.4.7	Continuous operation of components		N/A
B.4.8	Compliance during and after single fault conditions :	(See appended table B.3, B.4)	P
B.4.9	Battery charging and discharging under single fault conditions	See Table Annex M.	P
C	UV RADIATION		N/A
C.1	Protection of materials in equipment from UV radiation		N/A
C.1.2	Requirements		N/A
C.1.3	Test method		N/A
C.2	UV light conditioning test		N/A
C.2.1	Test apparatus..... :		N/A
C.2.2	Mounting of test samples		N/A
C.2.3	Carbon-arc light-exposure test		N/A

IEC/EN 62368-1			
Clause	Requirement + Test	Result - Remark	Verdict
C.2.4	Xenon-arc light-exposure test		N/A
D	TEST GENERATORS		N/A
D.1	Impulse test generators		N/A
D.2	Antenna interface test generator		N/A
D.3	Electronic pulse generator		N/A
E	TEST CONDITIONS FOR EQUIPMENT CONTAINING AUDIO AMPLIFIERS		N/A
E.1	Electrical energy source classification for audio signals		N/A
	Maximum non-clipped output power (W)		—
	Rated load impedance (Ω)		—
	Open-circuit output voltage (V).....		—
	Instructional safeguard.....		—
E.2	Audio amplifier normal operating conditions		N/A
	Audio signal source type.....		—
	Audio output power (W)		—
	Audio output voltage (V)		—
	Rated load impedance (Ω)		—
	Requirements for temperature measurement		N/A
E.3	Audio amplifier abnormal operating conditions		N/A
F	EQUIPMENT MARKINGS, INSTRUCTIONS, AND INSTRUCTIONAL SAFEGUARDS		P
F.1	General		P
	Language	Safety related equipment marking, instructions and instructional safeguards provided the English version. Other languages will be provided when submitted for national approval.	—
F.2	Letter symbols and graphical symbols		P
F.2.1	Letter symbols according to IEC60027-1	Letter symbols for quantities and units are complied with IEC 60027-1.	P
F.2.2	Graphic symbols according to IEC, ISO or manufacturer specific	Graphical symbols are complied with IEC 60417, ISO 3864-2, ISO 7000 or ISO 7010.	P
F.3	Equipment markings		P
F.3.1	Equipment marking locations		P

IEC/EN 62368-1			
Clause	Requirement + Test	Result - Remark	Verdict
F.3.2	Equipment identification markings		P
F.3.2.1	Manufacturer identification	See Copy of marking plate	P
F.3.2.2	Model identification	See Copy of marking plate	P
F.3.3	Equipment rating markings		P
F.3.3.1	Equipment with direct connection to mains	The equipment not mains connected	N/A
F.3.3.2	Equipment without direct connection to mains		P
F.3.3.3	Nature of the supply voltage	See Copy of marking plate	P
F.3.3.4	Rated voltage	See Copy of marking plate	P
F.3.3.5	Rated frequency		N/A
F.3.3.6	Rated current or rated power	See Copy of marking plate	P
F.3.3.7	Equipment with multiple supply connections		N/A
F.3.4	Voltage setting device		N/A
F.3.5	Terminals and operating devices		N/A
F.3.5.1	Mains appliance outlet and socket-outlet markings		N/A
F.3.5.2	Switch position identification marking		N/A
F.3.5.3	Replacement fuse identification and rating markings		N/A
	Instructional safeguards for neutral fuse.....		N/A
F.3.5.4	Replacement battery identification marking		N/A
F.3.5.5	Neutral conductor terminal		N/A
F.3.5.6	Terminal marking location		N/A
F.3.6	Equipment markings related to equipment classification		N/A
F.3.6.1	Class I equipment	Equipment is not of Class I equipment.	N/A
F.3.6.1.1	Protective earthing conductor terminal		N/A
F.3.6.1.2	Protective bonding conductor terminals		N/A
F.3.6.2	Equipment class marking		N/A
F.3.6.3	Functional earthing terminal marking.....		N/A
F.3.7	Equipment IP rating marking.....		N/A
F.3.8	External power supply output marking.....		N/A
F.3.9	Durability, legibility and permanence of marking		P

IEC/EN 62368-1			
Clause	Requirement + Test	Result - Remark	Verdict
F.3.10	Test for permanence of markings	The label was subjected to the permanence of marking test. The label was rubbed with cloth soaked with water for 15 sec. and then again for 15 sec. with the cloth soaked with Petroleum Spirit. After this test there was no damage to the label. The marking on the label did not fade. There was no curling or lifting of the label edge.	P
F.4	Instructions		P
	a) Information prior to installation and initial use		P
	b) Equipment for use in locations where children not likely to be present		N/A
	c) Instructions for installation and interconnection		P
	d) Equipment intended for use only in restricted access area		N/A
	e) Equipment intended to be fastened in place		N/A
	f) Instructions for audio equipment terminals		N/A
	g) Protective earthing used as a safeguard		N/A
	h) Protective conductor current exceeding ES2 limits		N/A
	i) Graphic symbols used on equipment		N/A
	j) Permanently connected equipment not provided with all-pole mains switch		N/A
	k) Replaceable components or modules providing safeguard function		N/A
	l) Equipment containing insulating liquid		N/A
	m) Installation instructions for outdoor equipment		N/A
F.5	Instructional safeguards		P
G	COMPONENTS		P
G.1	Switches		N/A
G.1.1	General		N/A
G.1.2	Ratings, endurance, spacing, maximum load		N/A
G.1.3	Test method and compliance		N/A
G.2	Relays		N/A
G.2.1	Requirements		N/A
G.2.2	Overload test		N/A

IEC/EN 62368-1			
Clause	Requirement + Test	Result - Remark	Verdict
G.2.3	Relay controlling connectors supplying power to other equipment		N/A
G.2.4	Test method and compliance		N/A
G.3	Protective devices		P
G.3.1	Thermal cut-offs		N/A
	Thermal cut-outs separately approved according to IEC 60730 with conditions indicated in a) & b)		N/A
	Thermal cut-outs tested as part of the equipment as indicated in c)		N/A
G.3.1.2	Test method and compliance		N/A
G.3.2	Thermal links		N/A
G.3.2.1	a) Thermal links tested separately according to IEC 60691 with specifics		N/A
	b) Thermal links tested as part of the equipment		N/A
G.3.2.2	Test method and compliance		N/A
G.3.3	PTC thermistors	Approved PTC Thermistors provided. See appended 4.1.2 for details.	P
G.3.4	Overcurrent protection devices		N/A
G.3.5	Safeguards components not mentioned in G.3.1 to G.3.4		N/A
G.3.5.1	Non-resettable devices suitably rated and marking provided		N/A
G.3.5.2	Single faults conditions		N/A
G.4	Connectors		N/A
G.4.1	Spacings		N/A
G.4.2	Mains connector configuration		N/A
G.4.3	Plug is shaped that insertion into mains socket-outlets or appliance coupler is unlikely		N/A
G.5	Wound components		N/A
G.5.1	Wire insulation in wound components		N/A
G.5.1.2	Protection against mechanical stress		N/A
G.5.2	Endurance test		N/A
G.5.2.1	General test requirements		N/A
G.5.2.2	Heat run test		N/A
	Test time (days per cycle)		—
	Test temperature (°C)		—
G.5.2.3	Wound components supplied from the mains		N/A

IEC/EN 62368-1			
Clause	Requirement + Test	Result - Remark	Verdict
G.5.2.4	No insulation breakdown		N/A
G.5.3	Transformers		N/A
G.5.3.1	Compliance method		N/A
	Position		N/A
	Method of protection		N/A
G.5.3.2	Insulation		N/A
	Protection from displacement of windings		—
G.5.3.3	Transformer overload tests		N/A
G.5.3.3.1	Test conditions		N/A
G.5.3.3.2	Winding temperatures		N/A
G.5.3.3.3	Winding temperatures - alternative test method		N/A
G.5.3.4	Transformers using FIW		N/A
G.5.3.4.1	General		N/A
	FIW wire nominal diameter		—
G.5.3.4.2	Transformers with basic insulation only		N/A
G.5.3.4.3	Transformers with double insulation or reinforced insulation		N/A
G.5.3.4.4	Transformers with FIW wound on metal or ferrite core		N/A
G.5.3.4.5	Thermal cycling test and compliance		N/A
G.5.3.4.6	Partial discharge test		N/A
G.5.3.4.7	Routine test		N/A
G.5.4	Motors		N/A
G.5.4.1	General requirements		N/A
G.5.4.2	Motor overload test conditions		N/A
G.5.4.3	Running overload test		N/A
G.5.4.4.2	Locked-rotor overload test		N/A
	Test duration (days)		—
G.5.4.5	Running overload test for DC motors		N/A
G.5.4.5.2	Tested in the unit		N/A
G.5.4.5.3	Alternative method		N/A
G.5.4.6	Locked-rotor overload test for DC motors		N/A
G.5.4.6.2	Tested in the unit		N/A
	Maximum Temperature		N/A
G.5.4.6.3	Alternative method		N/A

IEC/EN 62368-1			
Clause	Requirement + Test	Result - Remark	Verdict
G.5.4.7	Motors with capacitors		N/A
G.5.4.8	Three-phase motors		N/A
G.5.4.9	Series motors		N/A
	Operating voltage		—
G.6	Wire Insulation		N/A
G.6.1	General		N/A
G.6.2	Enamelled winding wire insulation		N/A
G.7	Mains supply cords		N/A
G.7.1	General requirements	Not provided mains supply cords.	N/A
	Type		—
G.7.2	Cross sectional area (mm ² or AWG)		N/A
G.7.3	Cord anchorages and strain relief for non-detachable power supply cords		N/A
G.7.3.2	Cord strain relief		N/A
G.7.3.2.1	Requirements		N/A
	Strain relief test force (N)		N/A
G.7.3.2.2	Strain relief mechanism failure		N/A
G.7.3.2.3	Cord sheath or jacket position, distance (mm)		N/A
G.7.3.2.4	Strain relief and cord anchorage material		N/A
G.7.4	Cord Entry		N/A
G.7.5	Non-detachable cord bend protection		N/A
G.7.5.1	Requirements		N/A
G.7.5.2	Test method and compliance		N/A
	Overall diameter or minor overall dimension, <i>D</i> (mm)		—
	Radius of curvature after test (mm)		—
G.7.6	Supply wiring space		N/A
G.7.6.1	General requirements		N/A
G.7.6.2	Stranded wire		N/A
G.7.6.2.1	Requirements		N/A
G.7.6.2.2	Test with 8 mm strand		N/A
G.8	Varistors		N/A
G.8.1	General requirements		N/A
G.8.2	Safeguards against fire		N/A

IEC/EN 62368-1			
Clause	Requirement + Test	Result - Remark	Verdict
G.8.2.1	General		N/A
G.8.2.2	Varistor overload test		N/A
G.8.2.3	Temporary overvoltage test		N/A
G.9	Integrated circuit (IC) current limiters		P
G.9.1	Requirements	Approved integrated circuit (IC) current limiters provided. (See appended tables 4.1.2)	P
	IC limiter output current (max. 5A)..... :		—
	Manufacturers' defined drift :		—
G.9.2	Test Program		N/A
G.9.3	Compliance		N/A
G.10	Resistors		N/A
G.10.1	General		N/A
G.10.2	Conditioning		N/A
G.10.3	Resistor test		N/A
G.10.4	Voltage surge test		N/A
G.10.5	Impulse test		N/A
G.10.6	Overload test		N/A
G.11	Capacitors and RC units		N/A
G.11.1	General requirements		N/A
G.11.2	Conditioning of capacitors and RC units		N/A
G.11.3	Rules for selecting capacitors		N/A
G.12	Optocouplers		N/A
	Optocouplers comply with IEC 60747-5-5 with specifics		N/A
	Type test voltage $V_{ini,a}$:		—
	Routine test voltage, $V_{ini,b}$:		—
G.13	Printed boards		N/A
G.13.1	General requirements		N/A
G.13.2	Uncoated printed boards		N/A
G.13.3	Coated printed boards		N/A
G.13.4	Insulation between conductors on the same inner surface		N/A
G.13.5	Insulation between conductors on different surfaces		N/A
	Distance through insulation..... :		N/A
	Number of insulation layers (pcs) :		—

IEC/EN 62368-1			
Clause	Requirement + Test	Result - Remark	Verdict
G.13.6	Tests on coated printed boards		N/A
G.13.6.1	Sample preparation and preliminary inspection		N/A
G.13.6.2	Test method and compliance		N/A
G.14	Coating on components terminals		N/A
G.14.1	Requirements		N/A
G.15	Pressurized liquid filled components		N/A
G.15.1	Requirements		N/A
G.15.2	Test methods and compliance		N/A
G.15.2.1	Hydrostatic pressure test		N/A
G.15.2.2	Creep resistance test		N/A
G.15.2.3	Tubing and fittings compatibility test		N/A
G.15.2.4	Vibration test		N/A
G.15.2.5	Thermal cycling test		N/A
G.15.2.6	Force test		N/A
G.15.3	Compliance		N/A
G.16	IC including capacitor discharge function (ICX)		N/A
G.16.1	Condition for fault tested is not required		N/A
	ICX with associated circuitry tested in equipment		N/A
	ICX tested separately		N/A
G.16.2	Tests		N/A
	Smallest capacitance and smallest resistance specified by ICX manufacturer for impulse test..... :		—
	Mains voltage that impulses to be superimposed on		—
	Largest capacitance and smallest resistance for ICX tested by itself for 10000 cycles test..... :		—
G.16.3	Capacitor discharge test		N/A
H	CRITERIA FOR TELEPHONE RINGING SIGNALS		N/A
H.1	General		N/A
H.2	Method A		N/A
H.3	Method B		N/A
H.3.1	Ringling signal		N/A
H.3.1.1	Frequency (Hz)		—
H.3.1.2	Voltage (V)		—
H.3.1.3	Cadence; time (s) and voltage (V)		—

IEC/EN 62368-1			
Clause	Requirement + Test	Result - Remark	Verdict
H.3.1.4	Single fault current (mA):		—
H.3.2	Tripping device and monitoring voltage		N/A
H.3.2.1	Conditions for use of a tripping device or a monitoring voltage		N/A
H.3.2.2	Tripping device		N/A
H.3.2.3	Monitoring voltage (V).....		N/A
J	INSULATED WINDING WIRES FOR USE WITHOUT INTERLEAVED INSULATION		N/A
J.1	General		N/A
	Winding wire insulation		—
	Solid round winding wire, diameter (mm).....		N/A
	Solid square and rectangular (flatwise bending) winding wire, cross-sectional area (mm ²)		N/A
J.2/J.3	Tests and Manufacturing		—
K	SAFETY INTERLOCKS		N/A
K.1	General requirements		N/A
	Instructional safeguard.....		N/A
K.2	Components of safety interlock safeguard mechanism		N/A
K.3	Inadvertent change of operating mode		N/A
K.4	Interlock safeguard override		N/A
K.5	Fail-safe		N/A
K.5.1	Under single fault condition		N/A
K.6	Mechanically operated safety interlocks		N/A
K.6.1	Endurance requirement		N/A
K.6.2	Test method and compliance		N/A
K.7	Interlock circuit isolation		N/A
K.7.1	Separation distance for contact gaps & interlock circuit elements		N/A
	In circuit connected to mains, separation distance for contact gaps (mm)		N/A
	In circuit isolated from mains, separation distance for contact gaps (mm)		N/A
	Electric strength test before and after the test of K.7.2.....		N/A
K.7.2	Overload test, Current (A).....		N/A
K.7.3	Endurance test		N/A
K.7.4	Electric strength test		N/A

IEC/EN 62368-1			
Clause	Requirement + Test	Result - Remark	Verdict
L	DISCONNECT DEVICES		N/A
L.1	General requirements		N/A
L.2	Permanently connected equipment		N/A
L.3	Parts that remain energized		N/A
L.4	Single-phase equipment		N/A
L.5	Three-phase equipment		N/A
L.6	Switches as disconnect devices		N/A
L.7	Plugs as disconnect devices		N/A
L.8	Multiple power sources		N/A
	Instructional safeguard..... :		N/A
M	EQUIPMENT CONTAINING BATTERIES AND THEIR PROTECTION CIRCUITS		P
M.1	General requirements		P
M.2	Safety of batteries and their cells		P
M.2.1	Batteries and their cells comply with relevant IEC standards :	See appended table 4.1.2 for RTC battery.	P
M.3	Protection circuits for batteries provided within the equipment		P
M.3.1	Requirements		P
M.3.2	Test method	RTC Battery is protected against charging current by multiple components.	P
	Overcharging of a rechargeable battery		N/A
	Excessive discharging		N/A
	Unintentional charging of a non-rechargeable battery	(See appended table Annex M.3)	P
	Reverse charging of a rechargeable battery		N/A
M.3.3	Compliance	(See appended table Annex M.3)	P
M.4	Additional safeguards for equipment containing a portable secondary lithium battery		N/A
M.4.1	General		N/A
M.4.2	Charging safeguards		N/A
M.4.2.1	Requirements		N/A
M.4.2.2	Compliance :		N/A
M.4.3	Fire enclosure..... :		N/A
M.4.4	Drop test of equipment containing a secondary lithium battery		N/A

IEC/EN 62368-1			
Clause	Requirement + Test	Result - Remark	Verdict
M.4.4.2	Preparation and procedure for the drop test		N/A
M.4.4.3	Drop, Voltage on reference and dropped batteries (V); voltage difference during 24 h period (%): :		N/A
M.4.4.4	Check of the charge/discharge function		N/A
M.4.4.5	Charge / discharge cycle test		N/A
M.4.4.6	Compliance		N/A
M.5	Risk of burn due to short-circuit during carrying		N/A
M.5.1	Requirement		N/A
M.5.2	Test method and compliance		N/A
M.6	Safeguards against short-circuits		N/A
M.6.1	External and internal faults		N/A
M.6.2	Compliance		N/A
M.7	Risk of explosion from lead acid and NiCd batteries		N/A
M.7.1	Ventilation preventing explosive gas concentration		N/A
	Calculated hydrogen generation rate..... :		N/A
M.7.2	Test method and compliance		N/A
	Minimum air flow rate, Q (m ³ /h)..... :		N/A
M.7.3	Ventilation tests		N/A
M.7.3.1	General		N/A
M.7.3.2	Ventilation test – alternative 1		N/A
	Hydrogen gas concentration (%)..... :		N/A
M.7.3.3	Ventilation test – alternative 2		N/A
	Obtained hydrogen generation rate..... :		N/A
M.7.3.4	Ventilation test – alternative 3		N/A
	Hydrogen gas concentration (%)..... :		N/A
M.7.4	Marking :		N/A
M.8	Protection against internal ignition from external spark sources of batteries with aqueous electrolyte		N/A
M.8.1	General		N/A
M.8.2	Test method		N/A
M.8.2.1	General		N/A
M.8.2.2	Estimation of hypothetical volume V_z (m ³ /s) :		—
M.8.2.3	Correction factors :		—
M.8.2.4	Calculation of distance d (mm) :		—
M.9	Preventing electrolyte spillage		N/A

IEC/EN 62368-1			
Clause	Requirement + Test	Result - Remark	Verdict
M.9.1	Protection from electrolyte spillage		N/A
M.9.2	Tray for preventing electrolyte spillage		N/A
M.10	Instructions to prevent reasonably foreseeable misuse		N/A
	Instructional safeguard..... :		N/A
N	ELECTROCHEMICAL POTENTIALS		N/A
	Material(s) used..... :		—
O	MEASUREMENT OF CREEPAGE DISTANCES AND CLEARANCES		N/A
	Value of X (mm)..... :		—
P	SAFEGUARDS AGAINST CONDUCTIVE OBJECTS		P
P.1	General		P
P.2	Safeguards against entry or consequences of entry of a foreign object		P
P.2.1	General		P
P.2.2	Safeguards against entry of a foreign object		P
	Location and Dimensions (mm) :	No openings	—
P.2.3	Safeguards against the consequences of entry of a foreign object		N/A
P.2.3.1	Safeguard requirements		N/A
	The ES3 and PS3 keep-out volume in Figure P.3 not applicable to transportable equipment		N/A
	Transportable equipment with metalized plastic parts..... :		N/A
P.2.3.2	Consequence of entry test..... :		N/A
P.3	Safeguards against spillage of internal liquids		N/A
P.3.1	General		N/A
P.3.2	Determination of spillage consequences		N/A
P.3.3	Spillage safeguards		N/A
P.3.4	Compliance		N/A
P.4	Metallized coatings and adhesives securing parts		N/A
P.4.1	General		N/A
P.4.2	Tests		N/A
	Conditioning, T _c (°C)..... :		—
	Duration (weeks) :		—
Q	CIRCUITS INTENDED FOR INTERCONNECTION WITH BUILDING WIRING		P
Q.1	Limited power sources		P
		See below.	
Q.1.1	Requirements		P

IEC/EN 62368-1			
Clause	Requirement + Test	Result - Remark	Verdict
	a) Inherently limited output		N/A
	b) Impedance limited output		P
	c) Regulating network limited output		P
	d) Overcurrent protective device limited output		N/A
	e) IC current limiter complying with G.9		P
Q.1.2	Test method and compliance	See appended table Q.1 for details.	P
	Current rating of overcurrent protective device (A)		N/A
Q.2	Test for external circuits – paired conductor cable		N/A
	Maximum output current (A)		N/A
	Current limiting method.....		—
R	LIMITED SHORT CIRCUIT TEST		N/A
R.1	General		N/A
R.2	Test setup		N/A
	Overcurrent protective device for test.....		—
R.3	Test method		N/A
	Cord/cable used for test.....		—
R.4	Compliance		N/A
S	TESTS FOR RESISTANCE TO HEAT AND FIRE		N/A
S.1	Flammability test for fire enclosures and fire barrier materials of equipment where the steady state power does not exceed 4 000 W		N/A
	Samples, material		—
	Wall thickness (mm)		—
	Conditioning (°C)		—
	Test flame according to IEC 60695-11-5 with conditions as set out		N/A
	- Material not consumed completely		N/A
	- Material extinguishes within 30s		N/A
	- No burning of layer or wrapping tissue		N/A
S.2	Flammability test for fire enclosure and fire barrier integrity		N/A
	Samples, material		—
	Wall thickness (mm)		—
	Conditioning (°C)		—
S.3	Flammability test for the bottom of a fire enclosure		N/A

IEC/EN 62368-1			
Clause	Requirement + Test	Result - Remark	Verdict
S.3.1	Mounting of samples		N/A
S.3.2	Test method and compliance		N/A
	Mounting of samples		—
	Wall thickness (mm)		—
S.4	Flammability classification of materials		N/A
S.5	Flammability test for fire enclosures and fire barrier materials of equipment where the steady state power exceeding 4 000 W		N/A
	Samples, material		—
	Wall thickness (mm)		—
	Conditioning (°C)		—
T	MECHANICAL STRENGTH TESTS		P
T.1	General		P
T.2	Steady force test, 10 N		N/A
T.3	Steady force test, 30 N		N/A
T.4	Steady force test, 100 N		N/A
T.5	Steady force test, 250 N	(See appended table T.2, T.3, T.4, T.5)	P
T.6	Enclosure impact test	(See appended table T.6, T.9)	P
	Fall test		P
	Swing test		N/A
T.7	Drop test		N/A
T.8	Stress relief test.....		N/A
T.9	Glass Impact Test.....		N/A
T.10	Glass fragmentation test		N/A
	Number of particles counted		N/A
T.11	Test for telescoping or rod antennas		N/A
	Torque value (Nm)		N/A
U	MECHANICAL STRENGTH OF CATHODE RAY TUBES (CRT) AND PROTECTION AGAINST THE EFFECTS OF IMPLOSION		N/A
U.1	General		N/A
	Instructional safeguard :		N/A
U.2	Test method and compliance for non-intrinsically protected CRTs		N/A
U.3	Protective screen		N/A
V	DETERMINATION OF ACCESSIBLE PARTS		P
V.1	Accessible parts of equipment		P

IEC/EN 62368-1			
Clause	Requirement + Test	Result - Remark	Verdict
V.1.1	General		P
V.1.2	Surfaces and openings tested with jointed test probes		P
V.1.3	Openings tested with straight unjointed test probes		P
V.1.4	Plugs, jacks, connectors tested with blunt probe		N/A
V.1.5	Slot openings tested with wedge probe		N/A
V.1.6	Terminals tested with rigid test wire		N/A
V.2	Accessible part criterion		P
X	ALTERNATIVE METHOD FOR DETERMINING CLEARANCES FOR INSULATION IN CIRCUITS CONNECTED TO AN AC MAINS NOT EXCEEDING 420 V PEAK (300 V RMS)		N/A
	Clearance :		N/A
Y	CONSTRUCTION REQUIREMENTS FOR OUTDOOR ENCLOSURES		N/A
Y.1	General		N/A
Y.2	Resistance to UV radiation		N/A
Y.3	Resistance to corrosion		N/A
Y.3	Resistance to corrosion		N/A
Y.3.1	Metallic parts of outdoor enclosures are resistant to effects of water-borne contaminants by :		N/A
Y.3.2	Test apparatus		N/A
Y.3.3	Water – saturated sulphur dioxide atmosphere		N/A
Y.3.4	Test procedure :		N/A
Y.3.5	Compliance		N/A
Y.4	Gaskets		N/A
Y.4.1	General		N/A
Y.4.2	Gasket tests		N/A
Y.4.3	Tensile strength and elongation tests		N/A
	Alternative test methods :		N/A
Y.4.4	Compression test		N/A
Y.4.5	Oil resistance		N/A
Y.4.6	Securing means		N/A
Y.5	Protection of equipment within an outdoor enclosure		N/A
Y.5.1	General		N/A
Y.5.2	Protection from moisture		N/A
	Relevant tests of IEC 60529 or Y.5.3 :		N/A
Y.5.3	Water spray test		N/A

IEC/EN 62368-1			
Clause	Requirement + Test	Result - Remark	Verdict
Y.5.4	Protection from plants and vermin		N/A
Y.5.5	Protection from excessive dust		N/A
Y.5.5.1	General		N/A
Y.5.5.2	IP5X equipment		N/A
Y.5.5.3	IP6X equipment		N/A
Y.6	Mechanical strength of enclosures		N/A
Y.6.1	General		N/A
Y.6.2	Impact test..... :		N/A

IEC 62368-1			
Clause	Requirement + Test	Result - Remark	Verdict

5.2	TABLE: Classification of electrical energy sources						P
Supply Voltage	Location (e.g. circuit designation)	Test conditions	Parameters				ES Class
			U (V)	I (mA)	Type ¹⁾	Additional Info ²⁾	
50 V d.c.	PoE LAN 3 (CN_LAN1A, Pin 1,2 – 3,6)	Normal	53.8 V d.c.	--	--	--	ES1
		Abnormal	53.8 V d.c.	--	--	--	ES1
		Single fault – D11 SC	54.0 V d.c.	--	--	--	ES1
50 V d.c.	Rear USB Type C (CN_TYPEC1), A4, A9, B4, B9 to GND	Normal	4.75 V d.c.	--	--	--	ES1
50 V d.c.	Front, Serial Port COM1 (COM1), pin 2, 3,8 to GND	Normal	5.30 V d.c.	--	--	--	ES1
50 V d.c.	Front, Isolated DIO (CN1), all pins to GND	Normal	0	--	--	--	ES1
50 V d.c.	Front, IGN (IGN1), pin 2 to GND		2.85 V d.c.				
50 V d.c.	Front, Mic-in, Line-out (AUDIO1); all pins to GND	Normal	0	--	--	--	ES1
50 V d.c.	Rear LAN1 (LAN1); all pins to GND	Normal	0	--	--	--	ES1
50 V d.c.	Rear USB2.0 (USB2_1), pin 1 to GND	Normal	5.01 V d.c.	--	--	--	ES1
50 V d.c.	Rear USB3.2 (CN_USB3X1), pin 1 to GND	Normal	5.01 V d.c.	--	--	--	ES1
50 V d.c.	Rear DP1 (CN_DP1); pin 20 to GND	Normal	3.37 V d.c.	--	--	--	ES1
50 V d.c.	Rear HDMI (HDMI1); pin 18 to GND	Normal	5.03 V d.c.	--	--	--	ES1

IEC 62368-1			
Clause	Requirement + Test	Result - Remark	Verdict

Supplementary information:

1) Type: Steady state (SS), Capacitance (CP), Single pulse (SP), Repetitive pulses (RP), etc.

2) Additional Info: Frequency, Pulse duration, Pulse off time, Capacitance value, etc.

3) Test conducted on LAN 3 to represent the other LAN 4, 5, 6 due to the same circuit.

 Test conducted on Front, Serial Port COM1 (COM1) to represent Front, Serial Port COM2-4 due to the same circuit.

 Test conducted on Rear DP1 (CN_DP1) to represent Rear DP2 (CN_DP2) due to the same circuit.

 Test conducted on Rear LAN1 (LAN1) to represent Rear LAN2 (LAN2), because the same circuit design.

5.4.1.8	TABLE: Working voltage measurement			N/A
Location	RMS voltage (V)	Peak voltage (V)	Frequency (Hz)	Comments
--	--	--	--	--
Supplementary information:				

5.4.1.10.2	TABLE: Vicat softening temperature of thermoplastics			N/A
Method..... :			ISO 306 / B50	—
Object/ Part No./Material	Manufacturer/trademark	Thickness (mm)	T softening (°C)	
--	--	--	--	
Supplementary information:				

5.4.1.10.3	TABLE: Ball pressure test of thermoplastics			N/A
Allowed impression diameter (mm)..... :			≤ 2 mm	—
Object/Part No./Material	Manufacturer/trademark	Thickness (mm)	Test temperature (°C)	Impression diameter (mm)
--	--	--	--	--
Supplementary information:				

5.4.2, 5.4.3	TABLE: Minimum Clearances/Creepage distance							N/A
Clearance (cl) and creepage distance (cr) at/of/between:	U _p (V)	U _{rms} (V)	Freq ¹⁾ (Hz)	Required cl (mm)	cl (mm)	E.S. ²⁾ (V)	Required cr (mm)	cr (mm)
--	--	--	--	--	--	--	--	--
Supplementary information:								
1) Only for frequency above 30 kHz								
2) Complete Electric Strength voltage (E.S. (V) when 5.4.2.4 applied)								

IEC 62368-1			
Clause	Requirement + Test	Result - Remark	Verdict

5.4.4.2	TABLE: Minimum distance through insulation				N/A
Distance through insulation (DTI) at/of	Peak voltage (V)	Insulation	Required DTI (mm)	Measured DTI (mm)	
--	--	--	--	--	
Supplementary information:					

5.4.4.9	TABLE: Solid insulation at frequencies >30 kHz						N/A
Insulation material	E_P	Frequency (kHz)	K_R	Thickness d (mm)	Insulation	V_{PW} (Vpk)	
--	--	--	--	--	--	--	
Supplementary information:							

5.4.9	TABLE: Electric strength tests				N/A
Test voltage applied between:		Voltage shape (Surge, Impulse, AC, DC, etc.)	Test voltage (V)	Breakdown Yes / No	
Functional:					
--		--	--	--	
Basic/supplementary:					
--		--	--	--	
Reinforced:					
--		--	--	--	
Supplementary information:					

5.5.2.2	TABLE: Stored discharge on capacitors					N/A
Location	Supply voltage (V)	Operating and fault condition ¹⁾	Switch position	Measured voltage (Vpk)	ES Class	
--	--	--	--	--	--	
Supplementary information:						
X-capacitors installed for testing:						
<input type="checkbox"/> bleeding resistor rating:						
<input type="checkbox"/> ICX:						
1) Normal operating condition (e.g., normal operation, or open fuse), SC= short circuit, OC= open circuit						

5.6.6	TABLE: Resistance of protective conductors and terminations			N/A
-------	---	--	--	-----

IEC 62368-1			
Clause	Requirement + Test	Result - Remark	Verdict

Location	Test current (A)	Duration (min)	Voltage drop (V)	Resistance (Ω)
--	--	--	--	--
Supplementary information:				

5.7.4	TABLE: Unearthed accessible parts					N/A
Location	Operating and fault conditions	Supply Voltage (V)	Parameters			ES class
			Voltage (V _{rms} or V _{pk})	Current (A _{rms} or A _{pk})	Freq. (Hz)	
--	--	--	--	--	--	--
Supplementary information:						
Abbreviation: SC= short circuit; OC= open circuit						

5.7.5	TABLE: Earthed accessible conductive part					N/A
Supply voltage (V).....:		--				--
Phase(s)		[] Single Phase; [] Three Phase: [] Delta [] Wye				--
Power Distribution System		<input type="checkbox"/> TN <input type="checkbox"/> TT <input type="checkbox"/> IT				--
Location	Fault Condition No in IEC 60990 clause 6.2.2	Touch current (mA)	Comment			
--	--	--	--			
Supplementary Information:						

5.8	TABLE: Backfeed safeguard in battery backed up supplies					N/A
Location	Supply voltage (V)	Operating and fault condition	Time (s)	Open-circuit voltage (V)	Touch current (A)	ES Class
--	--	--	--	--	--	--
Supplementary information:						
Abbreviation: SC= short circuit, OC= open circuit						

6.2.2	TABLE: Power source circuit classifications					P
Location	Operating and fault condition	Voltage (V)	Current (A)	Max. Power ¹⁾ (W)	Time (S)	PS class
Rear USB Type C (CN_TYPEC1), A4, A9, B4, B9 to GND	Worst-case fault	4.75	5.10	13.26	3	PS1
	Worst-case power source fault, U97 pin 1-12 SC	5.03	0.9	4.52	3	PS1

IEC 62368-1			
Clause	Requirement + Test	Result - Remark	Verdict

Supplementary information:
 Abbreviation: SC= short circuit; OC= open circuit
 1) Measured after 3 s for PS1 and measured after 5 s for PS2 and PS3.

6.2.3.1	TABLE: Determination of Arcing PIS				N/A
Location	Open circuit voltage after 3 s (Vpk)	Measured r.m.s current (A)	Calculated value	Arcing PIS? Yes / No	
--	--	--	--	--	
Supplementary information:					

6.2.3.2	TABLE: Determination of resistive PIS				N/A
Location	Operating and fault condition	Dissipate power (W)		Arcing PIS? Yes / No	
--	--	--		--	
Supplementary information: Abbreviation: SC= short circuit; OC= open circuit					

8.5.5	TABLE: High pressure lamp				N/A
Lamp manufacturer	Lamp type	Explosion method	Longest axis of glass particle (mm)	Particle found beyond 1 m Yes / No	
--	--	--	--	--	
Supplementary information:					

9.6	TABLE: Temperature measurements for wireless power transmitters								N/A
Supply voltage (V)..... :				--				---	
Max. transmit power of transmitter (W)				--				---	
Foreign objects	w/o receiver and direct contact		with receiver and direct contact		with receiver and at distance of 2 mm		with receiver and at distance of 5 mm		
	Object (°C)	Ambient (°C)	Object (°C)	Ambient (°C)	Object (°C)	Ambient (°C)	Object (°C)	Ambient (°C)	
--	--	--	--	--	--	--	--	--	
Supplementary information:									

IEC 62368-1			
Clause	Requirement + Test	Result - Remark	Verdict

5.4.1.4, 9.3, B.1.5, B.2.6	TABLE: Temperature measurements						P
Supply voltage (V)..... :		9 V d.c.	50 V d.c.	--	--	---	
Ambient temperature during test T_{amb} (°C) :		See below	See below	--	--	---	
Maximum measured temperature T of part/at:		T (°C)				Allowed T_{max} (°C)	
PCB near U1		82.3	88.6	--	--	130	
L29 body		91.9	98.5	--	--	130	
PCB near U68		84.1	91.7	--	--	130	
PCB near U95		86.4	96.0	--	--	130	
PCB near M38		83.5	93.6	--	--	130	
PCB near RAM		91.4	97.7	--	--	130	
PCB near M.2 SSD		89.3	98.1	--	--	130	
RTC battery		80.7	88.1	--	--	100	
L2 body		93.1	103.3	--	--	130	
T1 body		98.0	121.2	--	--	130	
C15 body		86.8	102.6	--	--	105	
USB 2.0 body		65.7	70.9	--	--	--	
USB 3.0 body		68.2	73.9	--	--	--	
Metal chassis outside near SSD		76.1	80.8	--	--	--	
Metal chassis outside near U1		73.0	79.9	--	--	--	
Ambient		45.0	45.0	--	--	--	
At room temperature							
USB-A 3.0 connector		53.5	55.5	--	--	70*	
USB-C Connector		54.4	57.5	--	--	70*	
Metal enclosure outside near SSD		61.9	66.1	--	--	70*	
Metal enclosure outside near U1		60.4	64.4	--	--	70*	
Ambient		25.4	25.6	--	--	--	
Temperature T of winding:	t_1 (°C)	R_1 (Ω)	t_2 (°C)	R_2 (Ω)	T (°C)	Allowed T_{max} (°C)	Insulation class
--	--	--	--	--	--	--	--
Supplementary information:							
*For Instructed person and Skilled person, the temperature limit for TS2 of accessible enclosure according							

IEC 62368-1			
Clause	Requirement + Test	Result - Remark	Verdict

to Table 38.

B.2.5	TABLE: Input test							P
U (V)	Hz	I (A)	I rated (A)	P (W)	P rated (W)	Fuse No	I fuse (A)	Condition/status
9 V d.c.	--	10.9	20	98.1	--	--	--	Maximum normal load
50 V d.c.	--	2.32	20	116.0	--	--	--	Maximum normal load
Supplementary information: Equipment may be have rated current or rated power or both. Both should be measured.								

B.3, B.4	TABLE: Abnormal operating and fault condition tests						P
Ambient temperature T_{amb} (°C).....					25 °C, if nothing else specified.		—
Power source for EUT: Manufacturer, model/type, outputrating ..					--		—
Component No.	Condition	Supply voltage (V)	Test time	Fuse no.	Fuse current (A)	Observation	
USB type C (CN_TYPEC1); pin A4, A9, B4, B9 to GND	Overload	50 V d.c.	3 hours 51 minutes	--	--	Temperature was stable at total USB load 4.0 A, Unit shut down at load 4.2 A, no hazardous, all safeguards remained effective. Metal chassis outside near U1: 66.0 °C, Metal chassis outside near SSD: 71.8 °C, USB-C Connector: 63.1 °C, USB-A 3.0 connector: 63.1 °C, Ambient: 26.0 °C	
Rear USB3.1 (CN_USB3X1); pin 1, 10 to GND	Overload	50 V d.c.	1 hours 8 minutes	--	--	Temperature was stable at total USB load 2.0 A, Unit shut down at load 2.1 A, no hazardous, all safeguards remained effective. Metal chassis outside near U1: 67.0 °C, Metal chassis outside near SSD: 70.8 °C, USB-C Connector: 66.2 °C, USB-A 3.0 connector: 64.2 °C, Ambient: 26.4 °C	

IEC 62368-1							
Clause	Requirement + Test				Result - Remark		Verdict
Rear USB2.1(USB2_1); pin 1, 5 to GND	Overload	50 V d.c.	2 hours 22 minutes	--	--	Temperature was stable at total USB load 2.1 A, Unit shut down at load 2.2 A, no hazardous, all safeguards remained effective. Metal chassis outside near U1: 66.1 °C, Metal chassis outside near SSD: 69.0 °C, USB-C Connector: 65.7 °C, USB-A 3.0 connector: 62.4 °C, Ambient: 25.9 °C	
D27 (1 to 2)	Short	50 V d.c.	7 hours	--	--	Unit operation normally, ASRE	
R426	Short	50 V d.c.	7 hours	--	--	Unit operation normally, ASRE	
Supplementary information: ASRE: All safeguards remained effectively.							

M.3	TABLE: Protection circuits for batteries provided within the equipment						P
Is it possible to install the battery in a reverse polarity position?.....:						No	—
Equipment Specification	Charging						
	Voltage (V)				Current (A)		
	9-50 V d.c.				20 A		
Manufacturer/type	Battery specification						
	Non-rechargeable batteries			Rechargeable batteries			
	Discharging current (A)	Unintentional charging current (A)	Charging		Discharging current (A)	Reverse charging current (A)	
			Voltage (V)	Current (A)			
TOHOKU MURATA MANUFACTURING CO., LTD. / Type CR2032W	--	10 mA	--	--	--	--	
Note: The tests of M.3.2 are applicable only when above appropriate data is not available.							
Specified battery temperature (°C)						100	
Component No.	Fault condition	Charge/discharge mode	Test time	Temp. (°C)	Current (A)	Voltage (V)	Observation
RTC battery	D27 (1 to 2)	Charge mode	7 hours	--	3.16 mA	3.14 V	NL、NS、NE、NF、ASRE
RTC battery	R426	Charge mode	7 hours	--	0 mA	3.14 V	NL、NS、NE、NF、

IEC 62368-1			
Clause	Requirement + Test	Result - Remark	Verdict

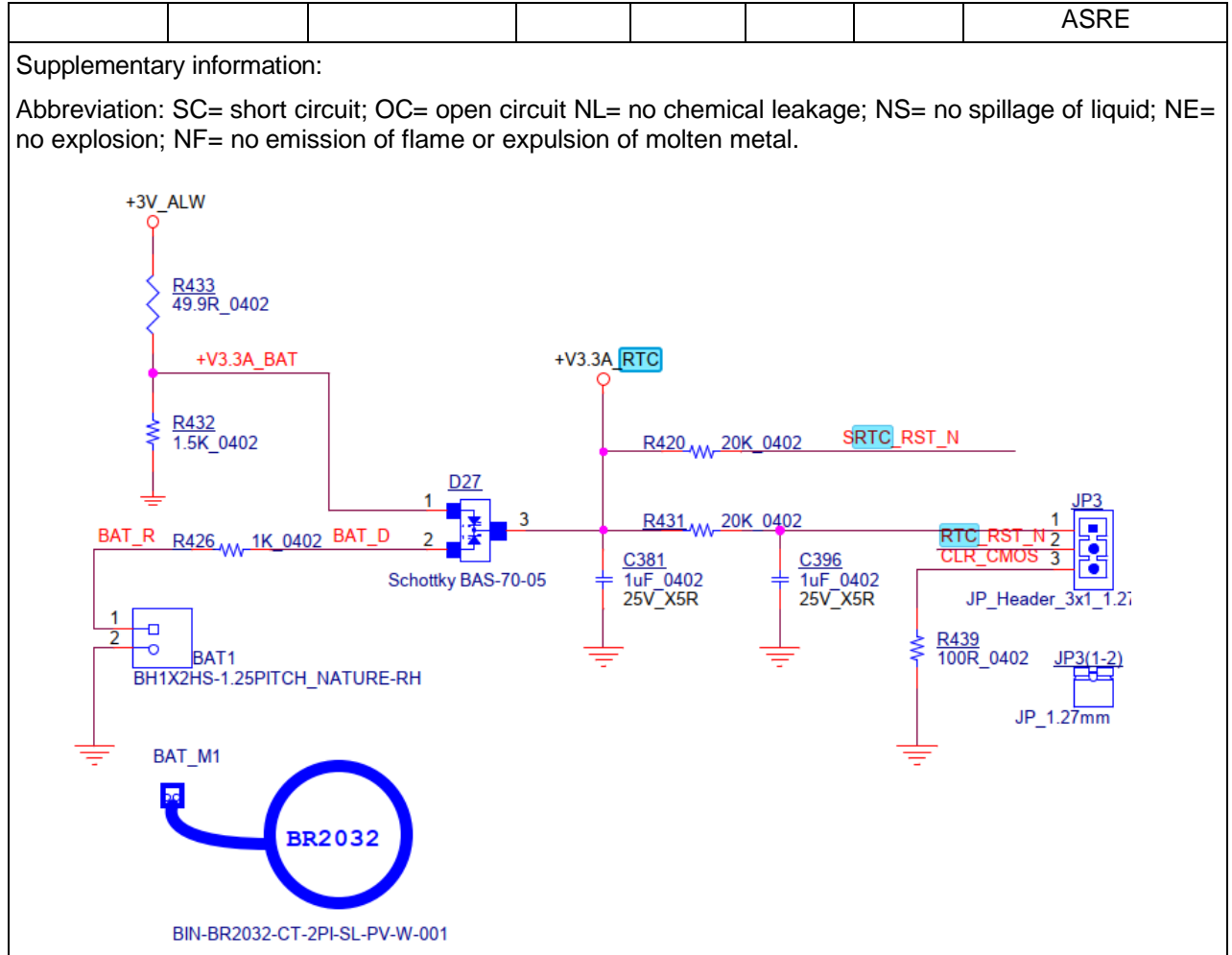

M.4.2	TABLE: Charging safeguards for equipment containing a secondary lithium battery				N/A
Maximum specified charging voltage (V)	--				---
Maximum specified charging current (A)	--				---
Highest specified charging temperature (°C)	--				
Lowest specified charging temperature (°C)	--				
Battery manufacturer/type	Operating and fault condition	Measurement			Observation
		Charging voltage (V)	Charging current (A)	Temp. (°C)	
--	--	--	--	--	--
Supplementary information:					
Abbreviation: SC= short circuit; OC= open circuit; MSCV= maximum specified charging voltage; MSCC= maximum specified charging current; HSCT= highest specified charging temperature; LSCT= lowest specified charging temperature					

IEC 62368-1			
Clause	Requirement + Test	Result - Remark	Verdict

Q.1	TABLE: Circuits intended for interconnection with building wiring (LPS)						P
Output Circuit	Condition	U _{oc} (V)	Time (s)	I _{sc} (A)		S (VA)	
				Meas.	Limit	Meas.	Limit
Front, Serial Port COM1 (COM1), pin 2, 3,8 to GND	Normal	5.30	5	0	8	0	100
Front, Serial Port COM1 (COM1), all other pins to GND	Normal	0	5	0	8	0	100
Front, PoE LAN 3 (CN_LAN1A, Pin 1,2 – 3,6)	Normal	53.80	5	0.70	8	36.26	100
Front, PoE LAN 3 (CN_LAN1A, Pin 1,2 – 3,6)	Single fault – D11 SC	54.0	5	0.70	8	36.60	100
Front, Isolated DIO (CN1), all pins to GND	Normal	0	5	0	8	0	100
Front, IGN (IGN1), pin 2 to GND	Normal	2.85	5	0	8	0	100
Front, IGN (IGN1), all other pins to GND	Normal	0	5	0	8	0	100
Front, Mic-in, Line-out (AUDIO1); all pins to GND	Normal	0	5	0	8	0	100
Rear LAN1 (LAN1); all pins to GND	Normal	0	5	0	8	0	100
Rear USB2.0 (USB2_1), pin 1 to GND	Normal	5.01	5	2.20	8	9.97	100
Rear USB2.0 (USB2_1), all other pins to GND	Normal	0	5	0	8	0	100
Rear USB3.2 (CN_USB3X1), pin 1 to GND	Normal	5.01	5	2.15	8	9.31	100
Rear USB3.2 (CN_USB3X1), all other pins to GND	Normal	0	5	0	8	0	100

IEC 62368-1			
Clause	Requirement + Test	Result - Remark	Verdict

Rear DP1 (CN_DP1); pin 20 to GND	Normal	3.37	5	5.8	8	11.35	100
Rear DP1 (CN_DP1); all other pins to GND	Normal	0	5	0	8	0	100
Rear HDMI (HDMI1); pin 18 to GND	Normal	5.03	5	2.50	8	8.10	100
Rear HDMI (HDMI_CN1); all other pins to GND	Normal	0	5	0	8	0	100

Supplementary Information:

Test voltage: 50 V d.c.

Test conducted on Front, Serial Port COM1 (COM1) to represent Front, Serial Port COM2-4 (COM2, J1, J2), because the same circuit design.

Test conducted on Rear DP1 (CN_DP1) to represent Rear DP2 (CN_DP2), because the same circuit design.

Test conducted on Rear LAN1 (LAN1) to represent Rear LAN2 (LAN2), because the same circuit design.

T.2, T.3, T.4, T.5	TABLE: Steady force test						P
Part/Location	Material	Thickness (mm)	Probe	Force (N)	Test Duration (s)	Observation	
Enclosure top	Metal	See table 4.1.2	--	250	5	Enclosure remained intact, no crack/ opening developed. Internal ES3, TS3 were not accessible after test.	
Enclosure side	Metal	See table 4.1.2	--	250	5	Enclosure remained intact, no crack/ opening developed. Internal ES3, TS3 were not accessible after test.	
Enclosure bottom	Metal	See table 4.1.2	--	250	5	Enclosure remained intact, no crack/ opening developed. Internal ES3, TS3 were not accessible after test.	

IEC 62368-1			
Clause	Requirement + Test	Result - Remark	Verdict

Supplementary information:

T.6, T.9	TABLE: Impact test				P
Location/part	Material	Thickness (mm)	Height (mm)	Observation	
Enclosure top	Metal	See table 4.1.2	1300	Enclosure remained intact, no crack/ opening developed. Internal ES3, TS3 were not accessible after test. No insulation breakdown	
Enclosure side	Metal	See table 4.1.2	1300	Enclosure remained intact, no crack/ opening developed. Internal ES3, TS3 were not accessible after test. No insulation breakdown	
Enclosure bottom	Metal	See table 4.1.2	1300	Enclosure remained intact, no crack/ opening developed. Internal ES3, TS3 were not accessible after test. No insulation breakdown	

Supplementary information:

T.7	TABLE: Drop test				N/A
Location/part	Material	Thickness (mm)	Height (mm)	Observation	
--	--	--	--	--	

Supplementary information:

T.8	TABLE: Stress relief test					N/A
Location/Part	Material	Thickness (mm)	Oven Temperature (°C)	Duration (h)	Observation	
--	--	--	--	--	--	

Supplementary information:

X	TABLE: Alternative method for determining minimum clearances distances			N/A
Clearance distanced between:	Peak of working voltage (V)	Required cl (mm)	Measured cl (mm)	
--	--	--	--	

IEC 62368-1			
Clause	Requirement + Test	Result - Remark	Verdict

Supplementary information:

IEC 62368-1			
Clause	Requirement + Test	Result - Remark	Verdict

4.1.2	TABLE: Critical components information					P
Object / part No.	Manufacturer/ trademark	Type / model	Technical data	Standard	Mark(s) of conformity ¹⁾	
Metal enclosure	Interchangeable	Interchangeable	1.0 mm thick. min.	--	--	
PCB	EISO ENTERPRISE CO LTD	6	V-0 min, 130°C min.	UL 796	UL	
Alt.	Interchangeable	Interchangeable	V-1 min., 130 °C min.	UL 796	UL	
RTC battery	TOHOKU MURATA MANUFACTURING CO., LTD	CR2032W	3 Vdc, maximum abnormal charging current 10 mA min.	UL 1642	UL	
Alt.	Interchangeable	CR2032W	3 Vdc, maximum abnormal charging current 10 mA min.	EN 60086-4, UL 1642	UL, Notify Body of CB Scheme or CENELEC or equivalent	
Polyswitch (F4) (for HDMI ports)	Polytronics Technology Corp.	SMD1812P11 0TF/33	33 V d.c., Ihold 1.1 A	IEC 62319-1- 1:2005 IEC 62319- 1:2005 EN 62319- 1:2005 EN 62319-1- 1:2005	TÜV Rheinland	
Polyswitch (F6, F3) (for DP ports)	Fuzetec Technology Co., Ltd.	FSMD300R	6 V d.c., 3.0 A	IEC 62319-1- 1:2005 IEC 62319- 1:2005 EN 62319- 1:2005 EN 62319-1- 1:2005	TÜV Rheinland	
Power Distribution Switch (U103, U105) (For Rear USB3.2)	Joulwatt Technology Co., Ltd.	JW7115S- 2SOTA	5.5Vdc, 2.0 A	IEC 62368-1	CB by UL	
Power Distribution Switch (U104) (For Rear USB2.0)	Joulwatt Technology Co., Ltd.	JW7115S- 2SOTA	5.5Vdc, 2.0 A	IEC 62368-1	CB by UL	

IEC 62368-1			
Clause	Requirement + Test	Result - Remark	Verdict

2.5 inch SATA Solid state drive (SSD) (two provided)	Innodisk Corporation	DGS25-C12M71EW3 QF-H03	5Vdc, 160mA	EN 62368-1	Test with appliance
Alt.	Interchangeable	Interchangeable	5Vdc, max. 160mA	EN 62368-1	Test with appliance

Supplementary information:

Interchangeability based on standardized dimensions and specified rating in above table.

ATTACHMENT 1- National differences

IEC62368_1E- ATTACHMENT			
Clause	Requirement + Test	Result - Remark	Verdict
ATTACHMENT TO TEST REPORT IEC 62368-1 EUROPEAN GROUP DIFFERENCES AND NATIONAL DIFFERENCES (AUDIO/VIDEO, INFORMATION AND COMMUNICATION TECHNOLOGY EQUIPMENT - PART 1: SAFETY REQUIREMENTS)			
Differences according to: EN IEC 62368-1:2020+A11:2020			
Attachment Form No.: EU_GD_IEC62368_1E			
Attachment Originator: UL(Demko)			
Master Attachment: 2021-02-04			
Copyright © 2021 IEC System for Conformity Testing and Certification of Electrical Equipment (IECEE), Geneva, Switzerland. All rights reserved.			
	CENELEC COMMON MODIFICATIONS (EN)		P
	Clause numbers in the cells that are shaded light grey are clause references in EN IEC 62368-1:2020+A11:2020. All other clause numbers in that column, except for those in the paragraph below, refers to IEC 62368-1:2018. Clauses, subclauses, notes, tables, figures and annexes which are additional to those in IEC 62368-1:2018 are prefixed "Z".		P
	Add the following annexes: Annex ZA (normative) Normative references to international publications with their corresponding European publications Annex ZB (normative) Special national conditions Annex ZC (informative) A-deviations Annex ZD (informative) IEC and CENELEC code designations for flexible cords		P
1	Modification to Clause 3 .		N/A
3.3.19	Sound exposure <i>Replace 3.3.19 of IEC 62368-1 with the following definitions:</i>		N/A

ATTACHMENT 1- National differences

IEC62368_1E- ATTACHMENT			
Clause	Requirement + Test	Result - Remark	Verdict
3.3.19.1	<p>momentary exposure level, MEL metric for estimating 1 s sound exposure level from the HD 483-1 S2 test signal applied to both channels, based on EN 50332-1:2013, 4.2. Note 1 to entry: MEL is measured as A-weighted levels in dB. Note 2 to entry: See B.3 of EN 50332-3:2017 for additional information.</p>		N/A
3.3.19.3	<p>sound exposure, E A-weighted sound pressure (p) squared and integrated over a stated period of time, T Note 1 to entry: The SI unit is Pa² s.</p> $E = \int_0^T p(t)^2 dt$		N/A
3.3.19.4	<p>sound exposure level, SEL logarithmic measure of sound exposure relative to a reference value, E_0, typically the 1 kHz threshold of hearing in humans. Note 1 to entry: SEL is measured as A-weighted levels in dB.</p> $SEL = 10 \lg \left(\frac{E}{E_0} \right) \text{ dB}$ <p>Note 2 to entry: See B.4 of EN 50332-3:2017 for additional information.</p>		N/A
3.3.19.5	<p>digital signal level relative to full scale, dBFS levels reported in dBFS are always r.m.s. Full scale level, 0 dBFS, is the level of a dc-free 997- Hz sine wave whose undithered positive peak value is positive digital full scale, leaving the code corresponding to negative digital full scale unused Note 1 to entry: It is invalid to use dBFS for non-r.m.s. levels. Because the definition of full scale is based on a sine wave, the level of signals with a crest factor lower than that of a sine wave may exceed 0 dBFS. In particular, square wave signals may reach +3,01 dBFS.</p>		N/A
2	Modification to Clause 10		N/A
10.6	Safeguards against acoustic energy sources Replace 10.6 of IEC 62368-1 with the following:		N/A
10.6.1.1	<p>Introduction Safeguard requirements for protection against long-term exposure to excessive sound pressure levels from personal music players closely coupled to the ear are specified below. Requirements for earphones and headphones intended for use with personal music players are also covered. A</p>		N/A

ATTACHMENT 1- National differences

IEC62368_1E- ATTACHMENT			
Clause	Requirement + Test	Result - Remark	Verdict
	<p>personal music player is a portable equipment intended for use by an ordinary person, that:</p> <ul style="list-style-type: none"> – is designed to allow the user to listen to audio or audiovisual content / material; and – uses a listening device, such as headphones or earphones that can be worn in or on or around the ears; and – has a player that can be body worn (of a size suitable to be carried in a clothing pocket) and is intended for the user to walk around with while in continuous use (for example, on a street, in a subway, at an airport, etc.). <p>EXAMPLES Portable CD players, MP3 audio players, mobile phones with MP3 type features, PDAs or similar equipment. Personal music players shall comply with the requirements of either 10.6.2 or 10.6.3.</p> <p>NOTE 1 Protection against acoustic energy sources from telecom applications is referenced to ITU-T P.360.</p> <p>NOTE 2 It is the intention of the Committee to allow the alternative methods for now, but to only use the dose measurement method as given in 10.6.5 in future. Therefore, manufacturers are encouraged to implement 10.6.5 as soon as possible. Listening devices sold separately shall comply with the requirements of 10.6.6. These requirements are valid for music or video mode only.</p> <p>The requirements do not apply to:</p> <ul style="list-style-type: none"> – professional equipment; <p>NOTE 3 Professional equipment is equipment sold through special sales channels. All products sold through normal electronics stores are considered not to be professional equipment.</p> <ul style="list-style-type: none"> – hearing aid equipment and other devices for assistive listening; – the following type of analogue personal music players: <ul style="list-style-type: none"> • long distance radio receiver (for example, a multiband radio receiver or world band radio receiver, an AM radio receiver), and • cassette player/recorder; <p>NOTE 4 This exemption has been allowed because this technology is falling out of use and it is expected that within a few years it will no longer exist. This exemption will not be extended to other technologies.</p> <ul style="list-style-type: none"> – a player while connected to an external amplifier that does not allow the user to walk around while in use. For equipment that is clearly designed or intended primarily for use by children, the limits of the relevant toy standards may apply. The relevant 		

ATTACHMENT 1- National differences

IEC62368_1E- ATTACHMENT			
Clause	Requirement + Test	Result - Remark	Verdict
	requirements are given in EN 71-1:2011, 4.20 and the related tests methods and measurement distances apply.		
10.6.1.2	<p>Non-ionizing radiation from radio frequencies in the range 0 to 300 GHz</p> <p>The amount of non-ionizing radiation is regulated by European Council Recommendation 1999/519/EC of 12 July 1999 on the limitation of exposure of the general public to electromagnetic fields (0 Hz to 300 GHz). For intentional radiators, ICNIRP guidelines should be taken into account for Limiting Exposure to Time-Varying Electric, Magnetic, and Electromagnetic Fields (up to 300 GHz). For hand-held and body mounted devices, attention is drawn to EN 50360 and EN 50566.</p>		N/A
10.6.2	Classification of devices without the capacity to estimate sound dose		N/A
10.6.2.1	<p>General</p> <p>This standard is transitioning from short-term based (30 s) requirements to long-term based (40 hour) requirements. These clauses remain in effect only for devices that do not comply with sound dose estimation as stipulated in EN 50332-3. For classifying the acoustic output $LA_{eq,T}$, measurements are based on the A-weighted equivalent sound pressure level over a 30 s period. For music where the average sound pressure (long term $LA_{eq,T}$) measured over the duration of the song is lower than the average produced by the programme simulation noise, measurements may be done over the duration of the complete song. In this case, T becomes the duration of the song.</p> <p>NOTE Classical music, acoustic music and broadcast typically has an average sound pressure (long term $LA_{eq,T}$) which is much lower than the average programme simulation noise. Therefore, if the player is capable to analyse the content and compare it with the programme simulation noise, the warning does not need to be given as long as the average sound pressure of the song does not exceed the required limit. For example, if the player is set with the programme simulation noise to 85 dB, but the average music level of the song is only 65 dB, there is no need to give a warning or ask an acknowledgement as long as the average sound level of the song is not above the basic limit of 85 dB.</p>		N/A
10.6.2.2	<p>RS1 limits (to be superseded, see 10.6.3.2)</p> <p>RS1 is a class 1 acoustic energy source that does not exceed the following:</p> <ul style="list-style-type: none"> – for equipment provided as a package (player with its listening device), and with a proprietary 		N/A



ATTACHMENT 1- National differences

IEC62368_1E- ATTACHMENT			
Clause	Requirement + Test	Result - Remark	Verdict
	<p>connector between the player and its listening device, or where the combination of player and listening device is known by other means such as setting or automatic detection, the $L_{Aeq,T}$ acoustic output shall be ≤ 85 dB when playing the fixed "programme simulation noise" described in EN 50332-1.</p> <ul style="list-style-type: none"> – for equipment provided with a standardized connector (for example, a 3,5 phone jack) that allows connection to a listening device for general use, the unweighted r.m.s. output voltage shall be ≤ 27 mV (analogue interface) or -25 dBFS (digital interface) when playing the fixed "programme simulation noise" described in EN 50332-1. – The RS1 limits will be updated for all devices as per 10.6.3.2. 		
10.6.2.3	<p>RS2 limits (to be superseded, see 10.6.3.3) RS2 is a class 2 acoustic energy source that does not exceed the following:</p> <ul style="list-style-type: none"> – for equipment provided as a package (player with its listening device), and with a proprietary connector between the player and its listening device, or when the combination of player and listening device is known by other means such as setting or automatic 130 detection, the $L_{Aeq,T}$ acoustic output shall be ≤ 100 dB(A) when playing the fixed "programme simulation noise" as described in EN 50332-1. – for equipment provided with a standardized connector (for example, a 3,5 phone jack) that allows connection to a listening device for general use, the unweighted r.m.s. output voltage shall be ≤ 150 mV (analogue interface) or -10 dBFS (digital interface) when playing the fixed "programme simulation noise" as described in EN 50332-1. 		N/A
10.6.2.4	<p>RS3 limits RS3 is a class 3 acoustic energy source that exceeds RS2 limits.</p>		N/A
10.6.3	Classification of devices (new)		N/A
10.6.3.1	<p>General Previous limits (10.6.2) created abundant false negative and false positive PMP sound level warnings. New limits, compliant with The Commission Decision of 23 June 2009, are given below.</p>		N/A
10.6.3.2	<p>RS1 limits (new) RS1 is a class 1 acoustic energy source that does not exceed the following:</p> <ul style="list-style-type: none"> – for equipment provided as a package (player with its listening device), and with a proprietary connector between the player and its listening 		N/A

ATTACHMENT 1- National differences

IEC62368_1E- ATTACHMENT			
Clause	Requirement + Test	Result - Remark	Verdict
	<p>device, or where the combination of player and listening device is known by other means such as setting or automatic detection, the $L_{Aeq,T}$ acoustic output shall be ≤ 80 dB when playing the fixed "programme simulation noise" described in EN 50332-1.</p> <p>– for equipment provided with a standardized connector (for example, a 3,5 phone jack) that allows connection to a listening device for general use, the unweighted r.m.s. output voltage shall be ≤ 15 mV (analogue interface) or -30 dBFS (digital interface) when playing the fixed "programme simulation noise" described in EN 50332-1.</p>		
10.6.3.3	<p>RS2 limits (new) RS2 is a class 2 acoustic energy source that does not exceed the following: – for equipment provided as a package (player with its listening device), and with a proprietary connector between the player and its listening device, or where the combination of player and listening device is known by other means such as setting or automatic detection, the weekly sound exposure level, as described in EN 50332-3, shall be ≤ 80 dB when playing the fixed "programme simulation noise" described in EN 50332-1. – for equipment provided with a standardized connector (for example, a 3,5 phone jack) that allows connection to a listening device for general use, the unweighted r.m.s. output level, integrated over one week, as described in EN50332-3, shall be ≤ 15 mV (analogue interface) or -30 dBFS (digital interface) when playing the fixed "programme simulation noise" described in EN 50332-1.</p>		N/A
10.6.4	Requirements for maximum sound exposure		N/A
10.6.4.1	<p>Measurement methods All volume controls shall be turned to maximum during tests. Measurements shall be made in accordance with EN 50332-1 or EN 50332-2 as applicable.</p>		N/A
10.6.4.2	<p>Protection of persons Except as given below, protection requirements for parts accessible to ordinary persons, instructed persons and skilled persons are given in 4.3. NOTE 1 Volume control is not considered a safeguard. Between RS2 and an ordinary person, the basic safeguard may be replaced by an instructional safeguard in accordance with Clause F.5, except that the instructional safeguard shall be placed on the equipment, or on the packaging, or in the instruction manual.</p>		N/A

ATTACHMENT 1- National differences

IEC62368_1E- ATTACHMENT			
Clause	Requirement + Test	Result - Remark	Verdict
	<p>Alternatively, the instructional safeguard may be given through the equipment display during use. The elements of the instructional safeguard shall be as follows:</p> <p style="text-align: center;">  </p> <ul style="list-style-type: none"> – element 1a: the symbol , IEC 60417-6044 (2011-01) – element 2: “High sound pressure” or equivalent wording – element 3: “Hearing damage risk” or equivalent wording – element 4: “Do not listen at high volume levels for long periods.” or equivalent wording <p>An equipment safeguard shall prevent exposure of an ordinary person to an RS2 source without intentional physical action from the ordinary person and shall automatically return to an output level not exceeding what is specified for an RS1 source when the power is switched off. The equipment shall provide a means to actively inform the user of the increased sound level when the equipment is operated with an output exceeding RS1. Any means used shall be acknowledged by the user before activating a mode of operation which allows for an output exceeding RS1. The acknowledgement does not need to be repeated more than once every 20 h of cumulative listening time.</p> <p>NOTE 2 Examples of means include visual or audible signals. Action from the user is always needed.</p> <p>NOTE 3 The 20 h listening time is the accumulative listening time, independent of how often and how long the personal music player has been switched off. A skilled person shall not be unintentionally exposed to RS3.</p>		
10.6.5	Requirements for dose-based systems		N/A
10.6.5.1	<p>General requirements</p> <p>Personal music players shall give the warnings as provided below when tested according to EN 50332-3, using the limits from this clause. The manufacturer may offer optional settings to allow the users to modify when and how they wish to receive the notifications and warnings to promote a better user experience without defeating the safeguards. This allows the users to be informed in a method that best meets their physical capabilities and device usage needs. If such optional settings are offered, an administrator (for example, parental restrictions, business/educational administrators, etc.) shall be able to lock any optional settings into</p>		N/A

ATTACHMENT 1- National differences

IEC62368_1E- ATTACHMENT			
Clause	Requirement + Test	Result - Remark	Verdict
	a specific configuration. The personal music player shall be supplied with easy to understand explanation to the user of the dose management system, the risks involved, and how to use the system safely. The user shall be made aware that other sources may significantly contribute to their sound exposure, for example work, transportation, concerts, clubs, cinema, car races, etc.		
10.6.5.2	Dose-based warning and requirements When a dose of 100 % CSD is reached, and at least at every 100 % further increase of CSD, the device shall warn the user and require an acknowledgement. In case the user does not acknowledge, the output level shall automatically decrease to compliance with class RS1. The warning shall at least clearly indicate that listening above 100 % CSD leads to the risk of hearing damage or loss.		N/A
10.6.5.3	Exposure-based requirements With only dose-based requirements, cause and effect could be far separated in time, defying the purpose of educating users about safe listening practice. In addition to dose-based requirements, a PMP shall therefore also put a limit to the short-term sound level a user can listen at. The exposure-based limiter (EL) shall automatically reduce the sound level not to exceed 100 dB(A) or 150 mV integrated over the past 180 s, based on methodology defined in EN 50332-3. The EL settling time (time from starting level reduction to reaching target output) shall be 10 s or faster. Test of EL functionality is conducted according to EN 50332-3, using the limits from this clause. For equipment provided as a package (player with its listening device), the level integrated over 180 s shall be 100 dB or lower. For equipment provided with a standardized connector, the unweighted level integrated over 180 s shall be no more than 150 mV for an analogue interface and no more than -10 dBFS for a digital interface. NOTE In case the source is known not to be music (or test signal), the EL may be disabled.		N/A
10.6.6	Requirements for listening devices (headphones, earphones, etc.)		N/A
10.6.6.1	Corded listening devices with analogue input With 94 dB LAeq acoustic pressure output of the listening device, and with the volume and sound settings in the listening device (for example, built-in volume level control, additional sound features like equalization, etc.) set to the combination of positions that maximize the measured acoustic output, the input voltage of the listening device		N/A

ATTACHMENT 1- National differences

IEC62368_1E- ATTACHMENT			
Clause	Requirement + Test	Result - Remark	Verdict
	when playing the fixed “programme simulation noise” as described in EN 50332-1 shall be ≥ 75 mV. NOTE The values of 94 dB and 75 mV correspond with 85 dB and 27 mV or 100 dB and 150 mV.		
10.6.6.2	Corded listening devices with digital input With any playing device playing the fixed “programme simulation noise” described in EN 50332-1, and with the volume and sound settings in the listening device (for example, built-in volume level control, additional sound features like equalization, etc.) set to the combination of positions that maximize the measured acoustic output, the $L_{Aeq, T}$ acoustic output of the listening device shall be ≤ 100 dB with an input signal of -10 dBFS.		N/A
10.6.6.3	Cordless listening devices In cordless mode, – with any playing and transmitting device playing the fixed programme simulation noise described in EN 50332-1; and – respecting the cordless transmission standards, where an air interface standard exists that specifies the equivalent acoustic level; and – with volume and sound settings in the receiving device (for example, built-in volume level control, additional sound features like equalization, etc.) set to the combination of positions that maximize the measured acoustic output for the above mentioned programme simulation noise, the $L_{Aeq, T}$ acoustic output of the listening device shall be ≤ 100 dB with an input signal of -10 dBFS.		N/A
10.6.6.4	Measurement method <i>Measurements shall be made in accordance with EN 50332-2 as applicable.</i>		N/A
3	Modification to the whole document		N/A

ATTACHMENT 1- National differences

IEC62368_1E- ATTACHMENT																																																																		
Clause	Requirement + Test				Result - Remark		Verdict																																																											
	<p>Delete all the “country” notes in the reference document according to the following list:</p> <table border="1"> <tr> <td>0.2.1</td> <td>Note 1 and 2</td> <td>1</td> <td>Note 4 and 5</td> <td>3.3.8.1</td> <td>Note 2</td> </tr> <tr> <td>3.3.8.3</td> <td>Note 1</td> <td>4.1.15</td> <td>Note</td> <td>4.7.3</td> <td>Note 1 and 2</td> </tr> <tr> <td>5.2.2.2</td> <td>Note</td> <td>5.4.2.3.2.2 Table 12</td> <td>Note c</td> <td>5.4.2.3.2.4</td> <td>Note 1 and 3</td> </tr> <tr> <td>5.4.2.3.2.4 Table 13</td> <td>Note 2</td> <td>5.4.2.5</td> <td>Note 2</td> <td>5.4.5.1</td> <td>Note</td> </tr> <tr> <td>5.4.10.2.1</td> <td>Note</td> <td>5.4.10.2.2</td> <td>Note</td> <td>5.4.10.2.3</td> <td>Note</td> </tr> <tr> <td>5.5.2.1</td> <td>Note</td> <td>5.5.6</td> <td>Note</td> <td>5.6.4.2.1</td> <td>Note 2 and 3 and 4</td> </tr> <tr> <td>5.6.8</td> <td>Note 2</td> <td>5.7.6</td> <td>Note</td> <td>5.7.7.1</td> <td>Note 1 and Note 2</td> </tr> <tr> <td>8.5.4.2.3</td> <td>Note</td> <td>10.2.1 Table 39</td> <td>Note 3 and 4 and 5</td> <td>10.5.3</td> <td>Note 2</td> </tr> <tr> <td>10.6.4</td> <td>Note 3</td> <td>F.3.3.6</td> <td>Note 3</td> <td>Y.4.1</td> <td>Note</td> </tr> <tr> <td>Y.4.5</td> <td>Note</td> <td></td> <td></td> <td></td> <td></td> </tr> </table>					0.2.1	Note 1 and 2	1	Note 4 and 5	3.3.8.1	Note 2	3.3.8.3	Note 1	4.1.15	Note	4.7.3	Note 1 and 2	5.2.2.2	Note	5.4.2.3.2.2 Table 12	Note c	5.4.2.3.2.4	Note 1 and 3	5.4.2.3.2.4 Table 13	Note 2	5.4.2.5	Note 2	5.4.5.1	Note	5.4.10.2.1	Note	5.4.10.2.2	Note	5.4.10.2.3	Note	5.5.2.1	Note	5.5.6	Note	5.6.4.2.1	Note 2 and 3 and 4	5.6.8	Note 2	5.7.6	Note	5.7.7.1	Note 1 and Note 2	8.5.4.2.3	Note	10.2.1 Table 39	Note 3 and 4 and 5	10.5.3	Note 2	10.6.4	Note 3	F.3.3.6	Note 3	Y.4.1	Note	Y.4.5	Note					N/A
0.2.1	Note 1 and 2	1	Note 4 and 5	3.3.8.1	Note 2																																																													
3.3.8.3	Note 1	4.1.15	Note	4.7.3	Note 1 and 2																																																													
5.2.2.2	Note	5.4.2.3.2.2 Table 12	Note c	5.4.2.3.2.4	Note 1 and 3																																																													
5.4.2.3.2.4 Table 13	Note 2	5.4.2.5	Note 2	5.4.5.1	Note																																																													
5.4.10.2.1	Note	5.4.10.2.2	Note	5.4.10.2.3	Note																																																													
5.5.2.1	Note	5.5.6	Note	5.6.4.2.1	Note 2 and 3 and 4																																																													
5.6.8	Note 2	5.7.6	Note	5.7.7.1	Note 1 and Note 2																																																													
8.5.4.2.3	Note	10.2.1 Table 39	Note 3 and 4 and 5	10.5.3	Note 2																																																													
10.6.4	Note 3	F.3.3.6	Note 3	Y.4.1	Note																																																													
Y.4.5	Note																																																																	
4	Modification to Clause 1					P																																																												
1	<p>Add the following note: <i>NOTE Z1 The use of certain substances in electrical and electronic equipment is restricted within the EU: see Directive 2011/65/EU.</i></p>				<p>Evaluated in National Approval.</p>		N/A																																																											

ATTACHMENT 1- National differences

IEC62368_1E- ATTACHMENT			
Clause	Requirement + Test	Result - Remark	Verdict
5	Modification to 4.Z1		N/A
4.Z1	<p>Add the following new subclause after 4.9: To protect against excessive current, short-circuits and earth faults in circuits connected to an a.c. mains, protective devices shall be included either as integral parts of the equipment or as parts of the building installation, subject to the following, a), b) and c):</p> <p>a) except as detailed in b) and c), protective devices necessary to comply with the requirements of B.3.1 and B.4 shall be included as parts of the equipment;</p> <p>b) for components in series with the mains input to the equipment such as the supply cord, appliance coupler, r.f.i. filter and switch, short-circuit and earth fault protection may be provided by protective devices in the building installation;</p> <p>c) it is permitted for pluggable equipment type B or permanently connected equipment, to rely on dedicated overcurrent and short-circuit protection in the building installation, provided that the means of protection, e.g. fuses or circuit breakers, is fully specified in the installation instructions. If reliance is placed on protection in the building installation, the installation instructions shall so state, except that for pluggable equipment type A the building installation shall be regarded as providing protection in accordance with the rating of the wall socket outlet.</p>		N/A
6	Modification to 5.4.2.3.2.4		N/A
5.4.2.3.2.4	<p>Add the following to the end of this subclause: The requirement for interconnection with external circuit is in addition given in EN 50491-3:2009.</p>		N/A
7	Modification to 10.2.1		N/A
10.2.1	<p>Add the following to ^{c)} and ^{d)} in table 39: For additional requirements, see 10.5.1.</p>		N/A

ATTACHMENT 1- National differences

IEC62368_1E- ATTACHMENT			
Clause	Requirement + Test	Result - Remark	Verdict
8	Modification to 10.5.1		N/A
10.5.1	<p>Add the following after the first paragraph: For RS 1 compliance is checked by measurement under the following conditions: In addition to the normal operating conditions, all controls adjustable from the outside by hand, by any object such as a tool or a coin, and those internal adjustments or pre-sets which are not locked in a reliable manner, are adjusted so as to give maximum radiation whilst maintaining an intelligible picture for 1 h, at the end of which the measurement is made. NOTE Z1 Soldered joints and paint lockings are examples of adequate locking. The dose-rate is determined by means of a radiation monitor with an effective area of 10 cm², at any point 10 cm from the outer surface of the apparatus. Moreover, the measurement shall be made under fault conditions causing an increase of the high voltage, provided an intelligible picture is maintained for 1 h, at the end of which the measurement is made. For RS1, the dose-rate shall not exceed 1 µSv/h taking account of the background level. NOTE Z2 These values appear in Directive 96/29/Euratom of 13 May 1996.</p>		N/A
9	Modification to G.7.1		N/A
G.7.1	<p>Add the following note: NOTE Z1 The harmonized code designations corresponding to the IEC cord types are given in Annex ZD.</p>		N/A

ATTACHMENT 1- National differences

IEC62368_1E- ATTACHMENT			
Clause	Requirement + Test	Result - Remark	Verdict
10	Modification to Bibliography		N/A
	<p>Add the following notes for the standards indicated:</p> <p>IEC 80130-9 NOTE Harmonized as EN 60130-9. IEC 80269-2 NOTE Harmonized as HD 60269-2. IEC 80309-1 NOTE Harmonized as EN 60309-1. IEC 80364 NOTE some parts harmonized in HD 384/HD 60364 series. IEC 80601-2-4 NOTE Harmonized as EN 60601-2-4. IEC 80664-5 NOTE Harmonized as EN 60664-5. IEC 81032:1997 NOTE Harmonized as EN 61032:1998 (not modified). IEC 81508-1 NOTE Harmonized as EN 61508-1. IEC 81558-2-1 NOTE Harmonized as EN 61558-2-1. IEC 81558-2-4 NOTE Harmonized as EN 61558-2-4. IEC 81558-2-6 NOTE Harmonized as EN 61558-2-6. IEC 81643-1 NOTE Harmonized as EN 61643-1. IEC 81643-21 NOTE Harmonized as EN 61643-21. IEC 81643-311 NOTE Harmonized as EN 61643-311. IEC 81643-321 NOTE Harmonized as EN 61643-321. IEC 81643-331 NOTE Harmonized as EN 61643-331.</p>		N/A
11	ADDITION OF ANNEXES		N/A
ZB	ANNEX ZB, SPECIAL NATIONAL CONDITIONS (EN)		N/A
4.1.15	<p>Denmark, Finland, Norway and Sweden To the end of the subclause the following is added: Class I pluggable equipment type A intended for connection to other equipment or a network shall, if safety relies on connection to reliable earthing or if surge suppressors are connected between the network terminals and accessible parts, have a marking stating that the equipment shall be connected to an earthed mains socket-outlet. The marking text in the applicable countries shall be as follows: In Denmark: "Apparatets stikprop skal tilsluttes en stikkontakt med jord som giver forbindelse til stikproppens jord." In Finland: "Laite on liitettävä suojakoskettimilla varustettuun pistorasiaan" In Norway: "Apparatet må tilkoples jordet stikkontakt" In Sweden: "Apparaten skall anslutas till jordat uttag"</p>		N/A

ATTACHMENT 1- National differences

IEC62368_1E- ATTACHMENT			
Clause	Requirement + Test	Result - Remark	Verdict
4.7.3	<p>United Kingdom To the end of the subclause the following is added: The torque test is performed using a socket-outlet complying with BS 1363, and the plug part shall be assessed to the relevant clauses of BS 1363. Also see Annex G.4.2 of this annex</p>		N/A
5.2.2.2	<p>Denmark After the 2nd paragraph add the following: A warning (marking safeguard) for high touch current is required if the touch current exceeds the limits of 3,5 mA a.c. or 10 mA d.c.</p>		N/A
5.4.11.1 and Annex G	<p>Finland and Sweden To the end of the subclause the following is added: For separation of the telecommunication network from earth the following is applicable: If this insulation is solid, including insulation forming part of a component, it shall at least consist of either</p> <ul style="list-style-type: none"> • two layers of thin sheet material, each of which shall pass the electric strength test below, or • one layer having a distance through insulation of at least 0,4 mm, which shall pass the electric strength test below. If this insulation forms part of a semiconductor component (e.g. an optocoupler), there is no distance through insulation requirement for the insulation consisting of an insulating compound completely filling the casing, so that clearances and creepage distances do not exist, if the component passes the electric strength test in accordance with the compliance clause below and in addition • passes the tests and inspection criteria of 5.4.8 with an electric strength test of 1,5 kV multiplied by 1,6 (the electric strength test of 5.4.9 shall be performed using 1,5 kV), and • is subject to routine testing for electric strength during manufacturing, using a test voltage of 1,5 kV. It is permitted to bridge this insulation with a capacitor complying with EN 60384-14:2005, subclass Y2. A capacitor classified Y3 according to EN 60384-14:2005, may bridge this insulation under the following conditions: <ul style="list-style-type: none"> • the insulation requirements are satisfied by having a capacitor classified Y3 as defined by EN 60384-14, which in addition to the Y3 testing, is tested with an impulse test of 2,5 kV defined in 5.4.11; • the additional testing shall be performed on all the test specimens as described in EN 60384-14; the impulse test of 2,5 kV is to be performed before the endurance test in EN 60384-14, in the sequence of tests as described in EN 60384-14. 		N/A

ATTACHMENT 1- National differences

IEC62368_1E- ATTACHMENT			
Clause	Requirement + Test	Result - Remark	Verdict
5.5.2.1	Norway After the 3rd paragraph the following is added: Due to the IT power system used, capacitors are required to be rated for the applicable line-to-line voltage (230 V).		N/A
5.5.6	Finland, Norway and Sweden To the end of the subclause the following is added: Resistors used as basic safeguard or bridging basic insulation in class I pluggable equipment type A shall comply with G.10.1 and the test of G.10.2.		N/A
5.6.1	Denmark Add to the end of the subclause Due to many existing installations where the socket-outlets can be protected with fuses with higher rating than the rating of the socket-outlets the protection for pluggable equipment type A shall be an integral part of the equipment. <i>Justification:</i> In Denmark an existing 13 A socket outlet can be protected by a 20 A fuse.		N/A
5.6.4.2.1	Ireland and United Kingdom After the indent for pluggable equipment type A , the following is added: – the protective current rating is taken to be 13 A, this being the largest rating of fuse used in the mains plug.		N/A
5.6.4.2.1	France After the indent for pluggable equipment type A , the following is added: – in certain cases, the protective current rating of the circuit supplied from the mains is taken as 20 A instead of 16 A.		N/A
5.6.5.1	To the second paragraph the following is added: The range of conductor sizes of flexible cords to be accepted by terminals for equipment with a rated current over 10 A and up to and including 13 A is: 1,25 mm ² to 1,5 mm ² in cross-sectional area.		N/A
5.6.8	Norway To the end of the subclause the following is added: Equipment connected with an earthed mains plug is classified as class I equipment . See the Norway marking requirement in 4.1.15. The symbol IEC 60417-6092, as specified in F.3.6.2, is accepted.		N/A
5.7.6	Denmark To the end of the subclause the following is added: The installation instruction shall be affixed to the equipment if the protective conductor current exceeds the limits of 3,5 mA a.c. or 10 mA d.c.		N/A
5.7.6.2	Denmark To the end of the subclause the following is added: The warning (marking safeguard) for high touch		N/A

ATTACHMENT 1- National differences

IEC62368_1E- ATTACHMENT			
Clause	Requirement + Test	Result - Remark	Verdict
	current is required if the touch current or the protective current exceed the limits of 3,5 mA .		
5.7.7.1	<p>Norway and Sweden</p> <p>To the end of the subclause the following is added: The screen of the television distribution system is normally not earthed at the entrance of the building and there is normally no equipotential bonding system within the building. Therefore the protective earthing of the building installation needs to be isolated from the screen of a cable distribution system. It is however accepted to provide the insulation external to the equipment by an adapter or an interconnection cable with galvanic isolator, which may be provided by a retailer, for example. The user manual shall then have the following or similar information in Norwegian and Swedish language respectively, depending on in what country the equipment is intended to be used in: "Apparatus connected to the protective earthing of the building installation through the mains connection or through other apparatus with a connection to protective earthing – and to a television distribution system using coaxial cable, may in some circumstances create a fire hazard. Connection to a television distribution system therefore has to be provided through a device providing electrical isolation below a certain frequency range (galvanic isolator, see EN 60728-11)"</p> <p>NOTE In Norway, due to regulation for CATV-installations, and in Sweden, a galvanic isolator shall provide electrical insulation below 5 MHz. The insulation shall withstand a dielectric strength of 1,5 kV r.m.s., 50 Hz or 60 Hz, for 1 min.</p> <p>Translation to Norwegian (the Swedish text will also be accepted in Norway): "Apparater som er koplet til beskyttelsesjord via nettplugg og/eller via annet jordtilkøpelt utstyr – og er tilkøpelt et koaksialbasert kabel-TV nett, kan forårsake brannfare. For å unngå dette skal det ved tilkøpling av apparater til kabel-TV nett installeres en galvanisk isolator mellom apparatet og kabel-TV nettet."</p> <p>Translation to Swedish: "Apparater som är kopplad till skyddsjord via jordat vägguttag och/eller via annan utrustning och samtidigt är kopplad till kabel-TV nät kan i vissa fall medföra risk för brand. För att undvika detta skall vid anslutning av apparaten till kabel-TV nät galvanisk isolator finnas mellan apparaten och kabel-TV nätet."</p>		N/A

ATTACHMENT 1- National differences

IEC62368_1E- ATTACHMENT			
Clause	Requirement + Test	Result - Remark	Verdict
8.5.4.2.3	<p>United Kingdom Add the following after the 2nd dash bullet in 3rd paragraph: An emergency stop system complying with the requirements of IEC 60204-1 and ISO 13850 is required where there is a risk of personal injury.</p>		N/A
B.3.1 and B.4	<p>Ireland and United Kingdom The following is applicable: To protect against excessive currents and short-circuits in the primary circuit of direct plug-in equipment, tests according to Annexes B.3.1 and B.4 shall be conducted using an external miniature circuit breaker complying with EN 60898-1, Type B, rated 32A. If the equipment does not pass these tests, suitable protective devices shall be included as an integral part of the direct plug-in equipment, until the requirements of Annexes B.3.1 and B.4 are met</p>		N/A
G.4.2	<p>Denmark To the end of the subclause the following is added: Supply cords of single phase appliances having a rated current not exceeding 13 A shall be provided with a plug according to DS 60884-2-D1:2011. CLASS I EQUIPMENT provided with socket-outlets with earth contacts or which are intended to be used in locations where protection against indirect contact is required according to the wiring rules shall be provided with a plug in accordance with standard sheet DK 2-1a or DK 2-5a. If a single-phase equipment having a RATED CURRENT exceeding 13 A or if a polyphase equipment is provided with a supply cord with a plug, this plug shall be in accordance with the standard sheets DK 6-1a in DS 60884-2-D1 or EN 60309-2. Mains socket outlets intended for providing power to Class II apparatus with a rated current of 2,5 A shall be in accordance DS 60884-2-D1:2011 standard sheet DKA 1-4a. Other current rating socket outlets shall be in compliance with Standard Sheet DKA 1-3a or DKA 1-1c. Mains socket-outlets with earth shall be in compliance with DS 60884-2-D1:2011 Standard Sheet DK 1-3a, DK 1-1c, DK1-1d, DK 1-5a or DK 1-7a <i>Justification:</i> Heavy Current Regulations, Section 6c</p>		N/A

ATTACHMENT 1- National differences

IEC62368_1E- ATTACHMENT			
Clause	Requirement + Test	Result - Remark	Verdict
G.4.2	<p>United Kingdom To the end of the subclause the following is added: The plug part of direct plug-in equipment shall be assessed to BS 1363: Part 1, 12.1, 12.2, 12.3, 12.9, 12.11, 12.12, 12.13, 12.16, and 12.17, except that the test of 12.17 is performed at not less than 125 °C. Where the metal earth pin is replaced by an Insulated Shutter Opening Device (ISOD), the requirements of clauses 22.2 and 23 also apply.</p>		N/A
G.7.1	<p>United Kingdom To the first paragraph the following is added: Equipment which is fitted with a flexible cable or cord and is designed to be connected to a mains socket conforming to BS 1363 by means of that flexible cable or cord shall be fitted with a 'standard plug' in accordance with the Plugs and Sockets etc. (Safety) Regulations 1994, Statutory Instrument 1994 No. 1768, unless exempted by those regulations. NOTE "Standard plug" is defined in SI 1768:1994 and essentially means an approved plug conforming to BS 1363 or an approved conversion plug.</p>		N/A
G.7.1	<p>Ireland To the first paragraph the following is added: Apparatus which is fitted with a flexible cable or cord shall be provided with a plug in accordance with Statutory Instrument 525: 1997, "13 A Plugs and Conversion Adapters for Domestic Use Regulations: 1997. S.I. 525 provides for the recognition of a standard of another Member State which is equivalent to the relevant Irish Standard</p>		N/A
G.7.2	<p>Ireland and United Kingdom To the first paragraph the following is added: A power supply cord with a conductor of 1,25 mm² is allowed for equipment which is rated over 10 A and up to and including 13 A.</p>		N/A
ZC	ANNEX ZC, NATIONAL DEVIATIONS (EN)		N/A

ATTACHMENT 1- National differences

IEC62368_1E- ATTACHMENT			
Clause	Requirement + Test	Result - Remark	Verdict
10.5.2	<p>Germany The following requirement applies: For the operation of any cathode ray tube intended for the display of visual images operating at an acceleration voltage exceeding 40 kV, authorization is required, or application of type approval (Bauartzulassung) and marking. <i>Justification:</i> German ministerial decree against ionizing radiation (Röntgenverordnung), in force since 2002-07-01, implementing the European Directive 96/29/EURATOM. NOTE Contact address: Physikalisch-Technische Bundesanstalt, Bundesallee 100, D-38116 Braunschweig, Tel.: Int+49-531-592-6320, Internet: http://www.ptb.de</p>		N/A

ATTACHMENT 1- National differences

IEC62368_1E- ATTACHMENT			
Clause	Requirement + Test	Result - Remark	Verdict

ZD	IEC and CENELEC CODE DESIGNATIONS FOR FLEXIBLE CORDS (EN)		N/A												
	<table border="1"> <thead> <tr> <th rowspan="2">Type of flexible cord</th> <th colspan="2">Code designations</th> </tr> <tr> <th>IEC</th> <th>CENELEC</th> </tr> </thead> </table>		Type of flexible cord	Code designations		IEC	CENELEC	N/A							
Type of flexible cord	Code designations														
	IEC	CENELEC													
	<p>PVC insulated cords</p> <table border="1"> <tr> <td>Flat twin tinsel cord</td> <td>60227 IEC 41</td> <td>H03VH-Y</td> </tr> <tr> <td>Light polyvinyl chloride sheathed flexible cord</td> <td>60227 IEC 52</td> <td>H03VV-F H03VVH2-F</td> </tr> <tr> <td>Ordinary polyvinyl chloride sheathed flexible cord</td> <td>60227 IEC 53</td> <td>H05VV-F H05VVH2-F</td> </tr> </table>		Flat twin tinsel cord	60227 IEC 41	H03VH-Y	Light polyvinyl chloride sheathed flexible cord	60227 IEC 52	H03VV-F H03VVH2-F	Ordinary polyvinyl chloride sheathed flexible cord	60227 IEC 53	H05VV-F H05VVH2-F				
Flat twin tinsel cord	60227 IEC 41	H03VH-Y													
Light polyvinyl chloride sheathed flexible cord	60227 IEC 52	H03VV-F H03VVH2-F													
Ordinary polyvinyl chloride sheathed flexible cord	60227 IEC 53	H05VV-F H05VVH2-F													
	<p>Rubber insulated cords</p> <table border="1"> <tr> <td>Braided cord</td> <td>60245 IEC 51</td> <td>H03RT-F</td> </tr> <tr> <td>Ordinary tough rubber sheathed flexible cord</td> <td>60245 IEC 53</td> <td>H05RR-F</td> </tr> <tr> <td>Ordinary polychloroprene sheathed flexible cord</td> <td>60245 IEC 57</td> <td>H05RN-F</td> </tr> <tr> <td>Heavy polychloroprene sheathed flexible cord</td> <td>60245 IEC 66</td> <td>H07RN-F</td> </tr> </table>		Braided cord	60245 IEC 51	H03RT-F	Ordinary tough rubber sheathed flexible cord	60245 IEC 53	H05RR-F	Ordinary polychloroprene sheathed flexible cord	60245 IEC 57	H05RN-F	Heavy polychloroprene sheathed flexible cord	60245 IEC 66	H07RN-F	
Braided cord	60245 IEC 51	H03RT-F													
Ordinary tough rubber sheathed flexible cord	60245 IEC 53	H05RR-F													
Ordinary polychloroprene sheathed flexible cord	60245 IEC 57	H05RN-F													
Heavy polychloroprene sheathed flexible cord	60245 IEC 66	H07RN-F													
	<p>Cords having high flexibility</p> <table border="1"> <tr> <td>Rubber insulated and sheathed cord</td> <td>60245 IEC 86</td> <td>H03RR-H</td> </tr> <tr> <td>Rubber insulated, crosslinked PVC sheathed cord</td> <td>60245 IEC 87</td> <td>H03RV4-H</td> </tr> <tr> <td>Crosslinked PVC insulated and sheathed cord</td> <td>60245 IEC 88</td> <td>H03V4V4-H</td> </tr> </table>		Rubber insulated and sheathed cord	60245 IEC 86	H03RR-H	Rubber insulated, crosslinked PVC sheathed cord	60245 IEC 87	H03RV4-H	Crosslinked PVC insulated and sheathed cord	60245 IEC 88	H03V4V4-H				
Rubber insulated and sheathed cord	60245 IEC 86	H03RR-H													
Rubber insulated, crosslinked PVC sheathed cord	60245 IEC 87	H03RV4-H													
Crosslinked PVC insulated and sheathed cord	60245 IEC 88	H03V4V4-H													
	<p>Cords insulated and sheathed with halogen-free thermoplastic compounds</p> <table border="1"> <tr> <td>Light halogen-free thermoplastic insulated and sheathed flexible cords</td> <td></td> <td>H03Z1Z1-F H03Z1Z1H2-F</td> </tr> <tr> <td>Ordinary halogen-free thermoplastic insulated and sheathed flexible cords</td> <td></td> <td>H05Z1Z1-F H05Z1Z1H2-F</td> </tr> </table>		Light halogen-free thermoplastic insulated and sheathed flexible cords		H03Z1Z1-F H03Z1Z1H2-F	Ordinary halogen-free thermoplastic insulated and sheathed flexible cords		H05Z1Z1-F H05Z1Z1H2-F							
Light halogen-free thermoplastic insulated and sheathed flexible cords		H03Z1Z1-F H03Z1Z1H2-F													
Ordinary halogen-free thermoplastic insulated and sheathed flexible cords		H05Z1Z1-F H05Z1Z1H2-F													

ATTACHMENT 2- Photographs

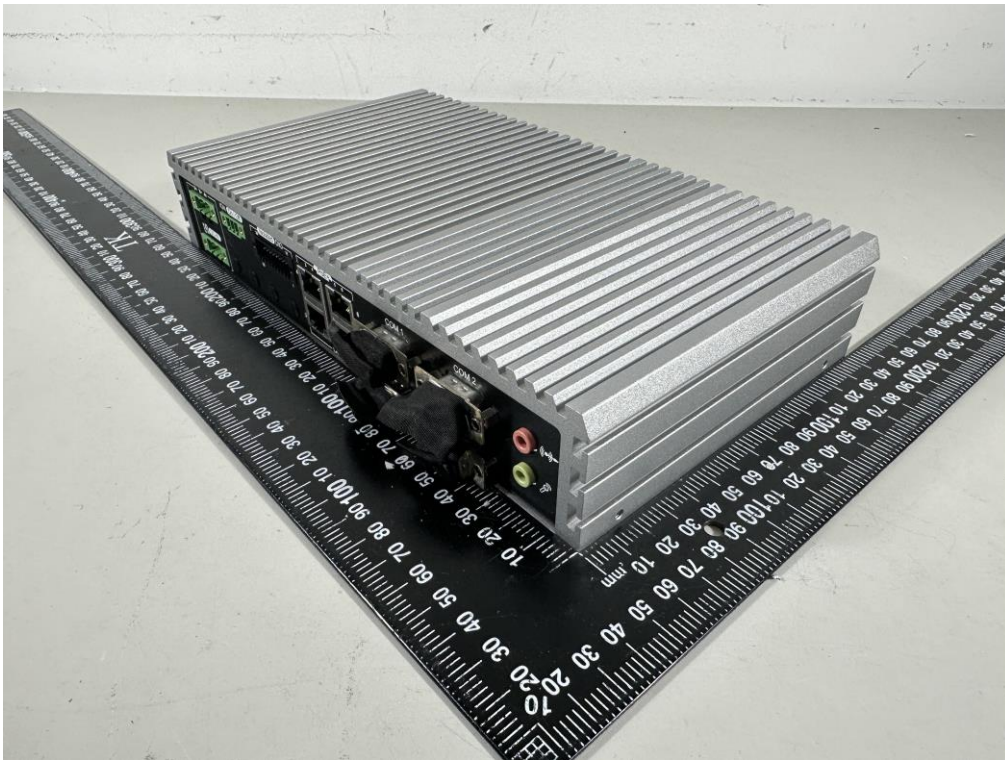

ATTACHMENT 2- Photographs



ATTACHMENT 2- Photographs

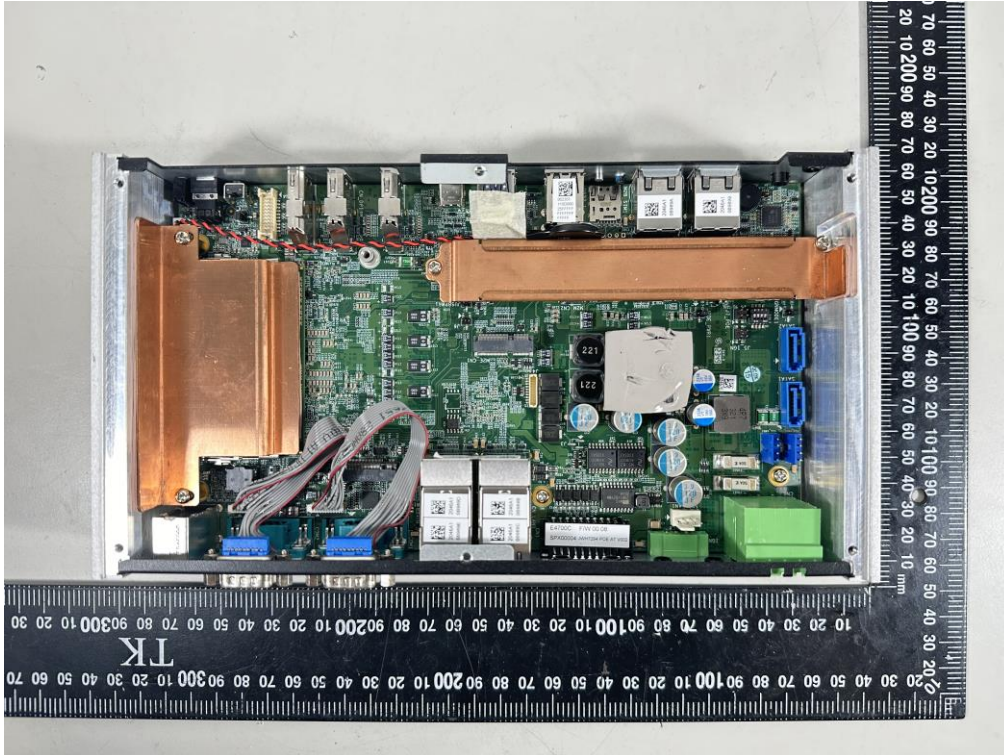
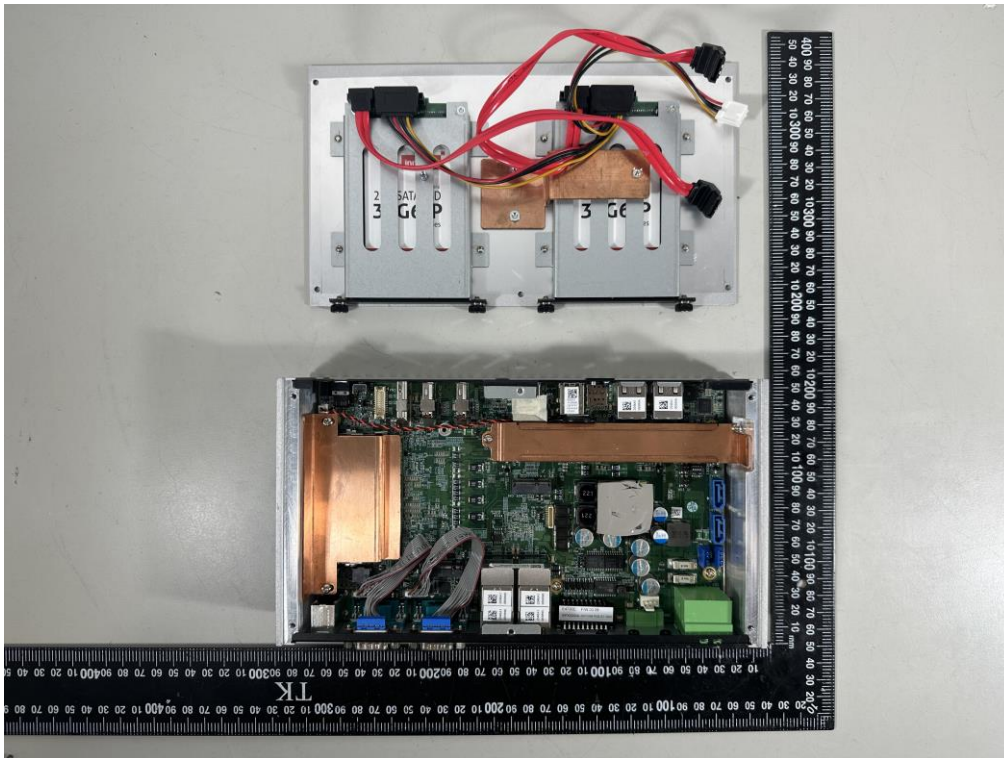

ATTACHMENT 2- Photographs

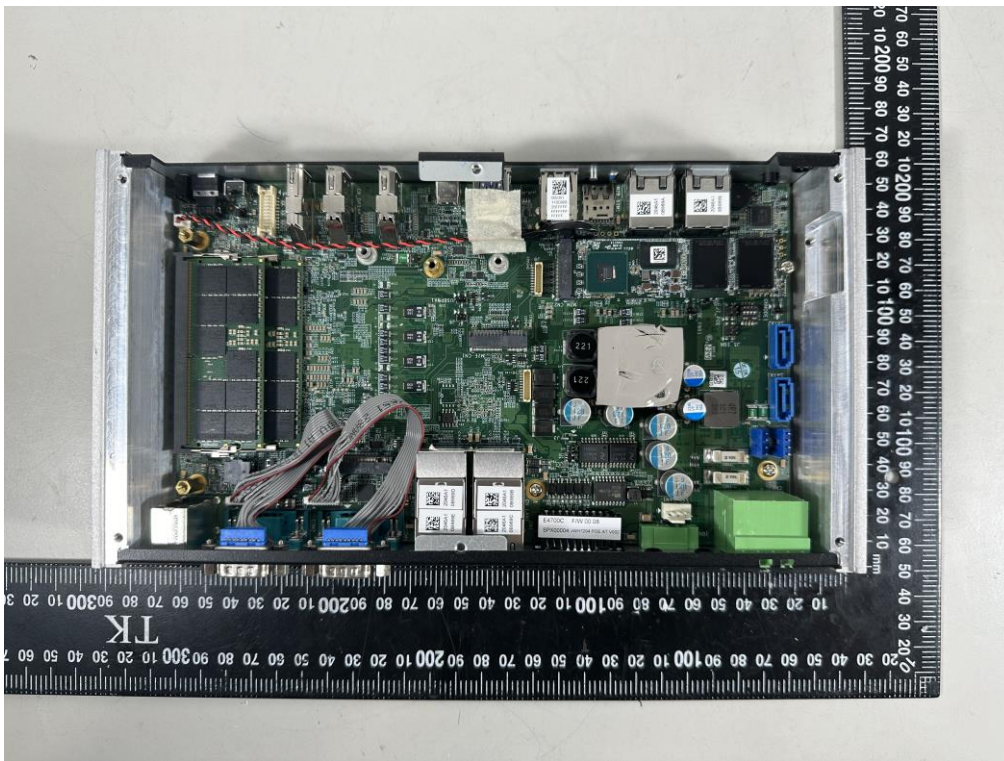

ATTACHMENT 2- Photographs

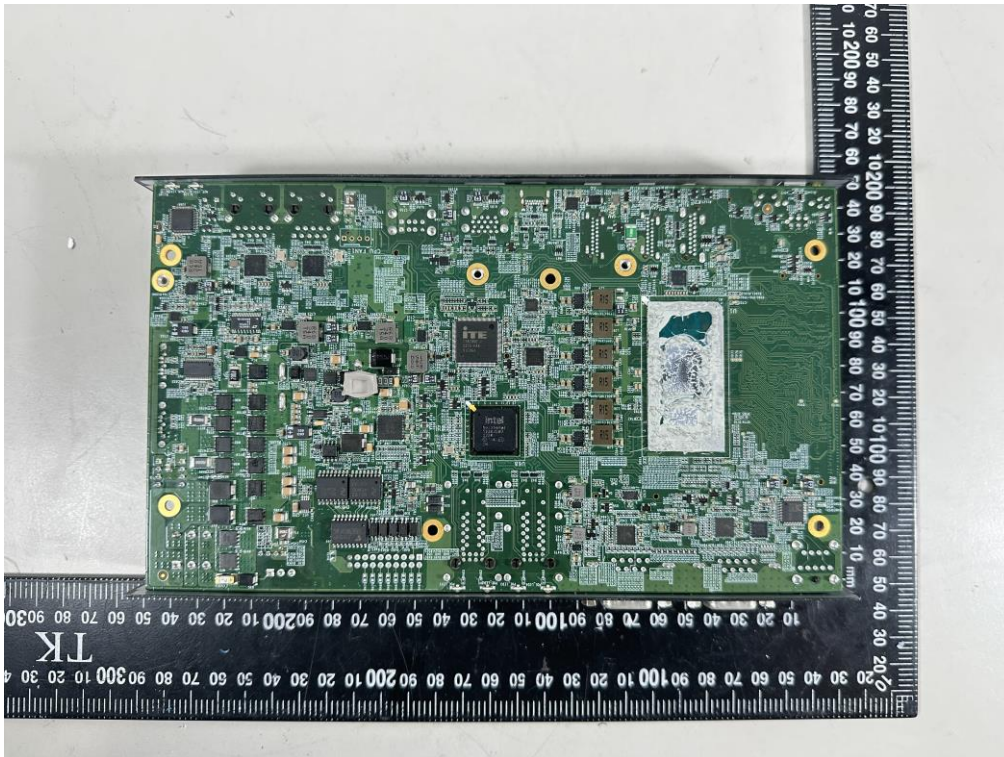

-End of report-